



TAOGLAS®



Datasheet

Part No:
PA.433.A

Description

433 MHz or Alternative 433, 868 & 915 MHz Combined Ceramic SMD Antenna
30.0 x 10.0 x 5.0 mm

Features:

Compact 433 MHz Ceramic SMD Antenna
Alternative Configuration to cover 433, 868 and 915 MHz together
Frequency Range: 433 - 435 MHz and 433, 868 and 915 MHz Combined
Dims: 30.0 x 10.0 x 5.0 mm
AEC-Q200 Qualified
RoHS & Reach Compliant

| | | |
|-----------|--|-----------|
| 1. | Introduction | 3 |
| 2. | Specification | 4 |
| 3. | Mechanical Drawing | 5 |
| 4. | Antenna Integration Guide | 6 |
| 5. | Packaging | 15 |
| 6. | Antenna Characteristics | 17 |
| 7. | Radiation Patterns | 23 |
| 8. | Application Note – Copper Clearance | 28 |
| <hr/> | | |
| | Changelog | 32 |

Taoglas makes no warranties based on the accuracy or completeness of the contents of this document and reserves the right to make changes to specifications and product descriptions at any time without notice. Taoglas reserves all rights to this document and the information contained herein. Reproduction, use or disclosure to third parties without express permission is strictly prohibited.

Ireland & USA
ISO 9001:2015
Certified



Taiwan
ISO 9001:2015
Certified



1. Introduction



The **PA.433.A** is a compact, high-performance ceramic SMD antenna designed for reliable wireless communication in the 433 MHz ISM band and fully AEC-Q200 qualified. Its robust ceramic structure ensures long-term durability, while the surface-mount design simplifies integration into compact PCB layouts. With an omnidirectional radiation pattern and stable electrical characteristics, the PA.433.A delivers consistent performance across diverse environments, even if the orientation of the device is not known.

The antenna can be implemented in two different configurations depending on application requirements. A dedicated matching circuit enables operation in a single-band 433 MHz configuration, while an alternative matching circuit allows for multi-band performance covering 433 / 868 / 915 MHz. Both matching circuits are provided in this document, along with corresponding specification tables and measured performance graphs for each configuration.

Typical applications include:

- Smart Metering (water, gas, and electricity meters)
- Remote Keyless Entry (RKE) systems
- Industrial Control and automation equipment
- Wireless Sensor Networks (WSN)
- Home and Building Automation
- Remote Monitoring Systems
- Security and Access Control Devices

Engineered for ease of integration, the PA.433.A is ideally suited for space-constrained designs that require reliable, long-range sub-GHz communication.

For further optimization to customer-specific device environments and for support to integrate and test this antennas performance in your device, contact your regional Taoglas Customer Services Team.

2. Specification

Electrical for 433MHz Tuning Configuration

| Band | Frequency (MHz) | Efficiency (%) | Average Gain (dB) | Peak Gain (dBi) | Impedance | Polarization | Radiation Pattern | Max. input power |
|--------|-----------------|----------------|-------------------|-----------------|-------------|--------------|-------------------|------------------|
| 433MHz | 433-435 | 36.3 | -4.40 | -1.15 | 50 Ω | Linear | Omni directional | 10W |

Electrical for 433/868/915MHz Tuning Configuration

| Band | Frequency (MHz) | Efficiency (%) | Average Gain (dB) | Peak Gain (dBi) | Impedance | Polarization | Radiation Pattern | Max. input power |
|--------|-----------------|----------------|-------------------|-----------------|-------------|--------------|-------------------|------------------|
| 433MHz | 430-436 | 22.0 | -6.57 | -2.65 | 50 Ω | Linear | Omni directional | 10W |
| 868MHz | 862-874 | 38.2 | -4.18 | 0.23 | | | | |
| 915MHz | 910-920 | 42.3 | -3.74 | 0.23 | | | | |

Mechanical

| | |
|------------|------------------------------|
| Dimensions | 30.0 mm x 10.0 mm x 5.0 mm |
| Weight | 6g |
| Material | Ceramic (AEC-Q200 qualified) |
| Mount | SMT |

Environmental

| | |
|-----------------------|----------------|
| Operation Temperature | -40°C to 105°C |
| Storage Temperature | -40°C to 125°C |
| MSL | 3 |

3. Mechanical Drawing

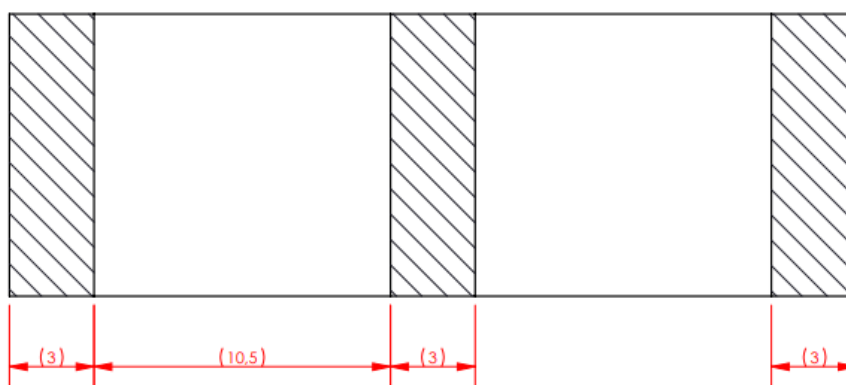
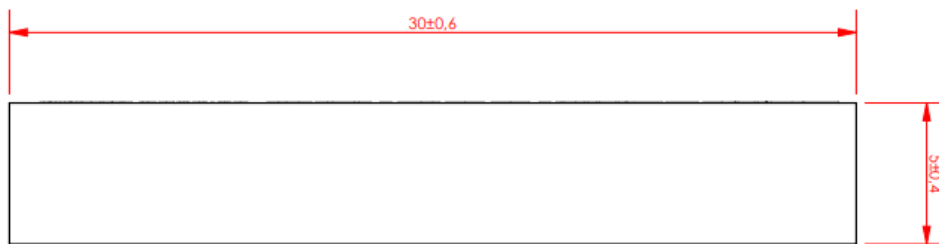
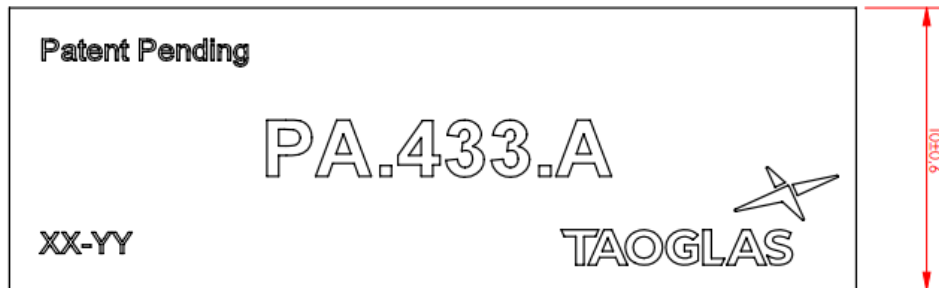

4. Antenna Integration Guide

The following is an example on how to integrate the PA.433.A into a design. This antenna has 3 pins, where one pin is used for the RF Feed. Taoglas recommends using a minimum of 149 x 50 mm ground plane (PCB) to ensure optimal performance.



Top view of PCB reference design

4.1 Schematic Symbol and Pin Definitions



Above is a 3D model of the PA.433.A on a PCB reference design

The circuit symbol for the PA.433.A is shown below. The antenna has 3 pins as indicated below.

| Pin | Description |
|------|---------------------------|
| 1 | RF Feed |
| 2, 3 | Mechanical, No Connection |

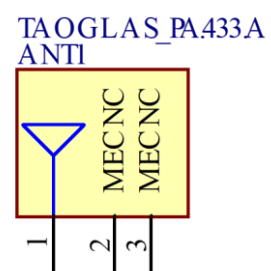

4.2 Schematic Layout for 433MHz Tuning

Matching components with the PA.433.A are required for the antenna to have optimal performance in the spaces specified in the schematic below. Additional matching components may be necessary for your device, Taoglas recommends incorporating extra component footprints, forming a “pi” network, for the PA.433.A.

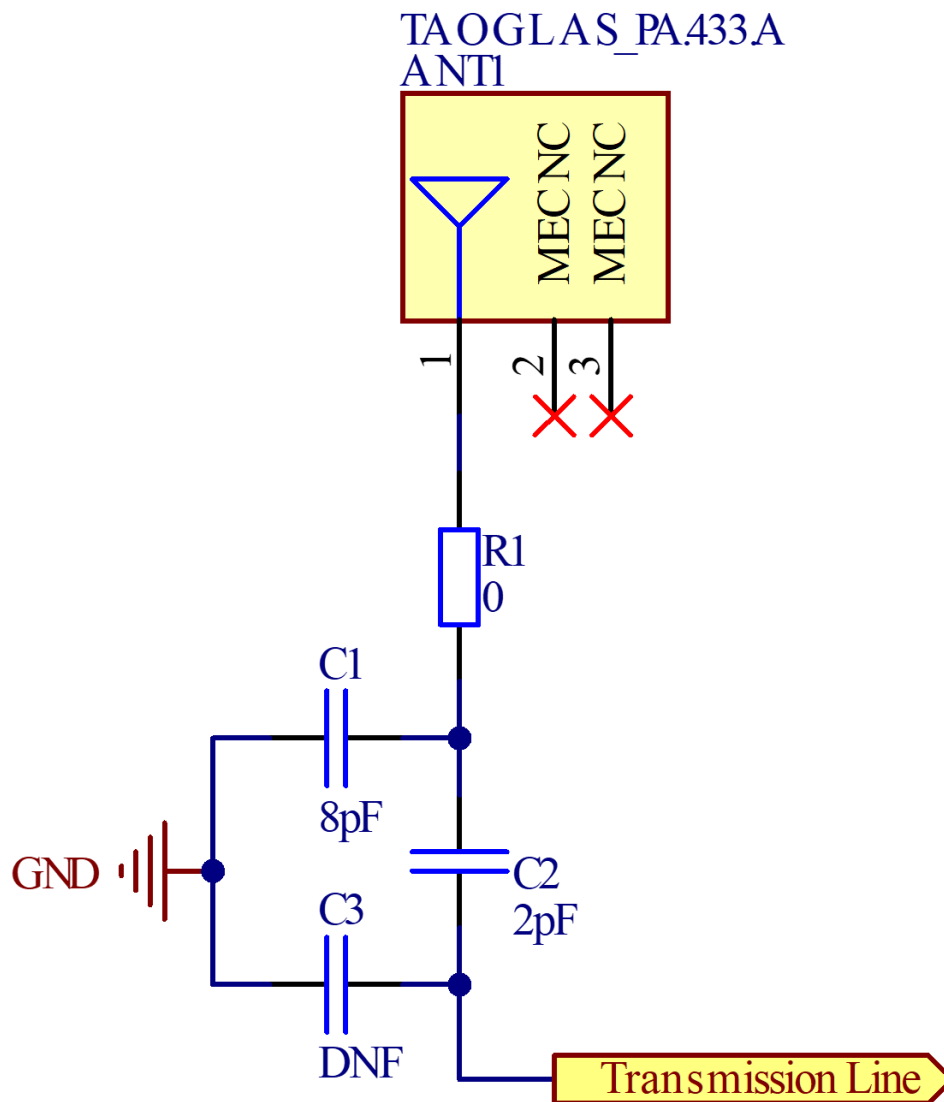

| Designator | Type | Value | Manufacturer | Manufacturer Part Number |
|------------|-----------|------------|--------------|--------------------------|
| C1 | Capacitor | 8pF | Murata | GJM1555C1H8R0BB01D |
| C2 | Capacitor | 2pF | Murata | GRM1555C1H2R0BA01D |
| C3 | Capacitor | Not Fitted | - | - |
| R1 | Resistor | 0 Ohm | YAGEO | RC0402JR-070RL |

4.3 Schematic Layout for 433/868/915MHz Tuning

Matching components with the PA.433.A are required for the antenna to have optimal performance in the spaces specified in the schematic below. Additional matching components may be necessary for your device, Taoglas recommends incorporating extra component footprints, forming a “pi” network, for the PA.433.A.

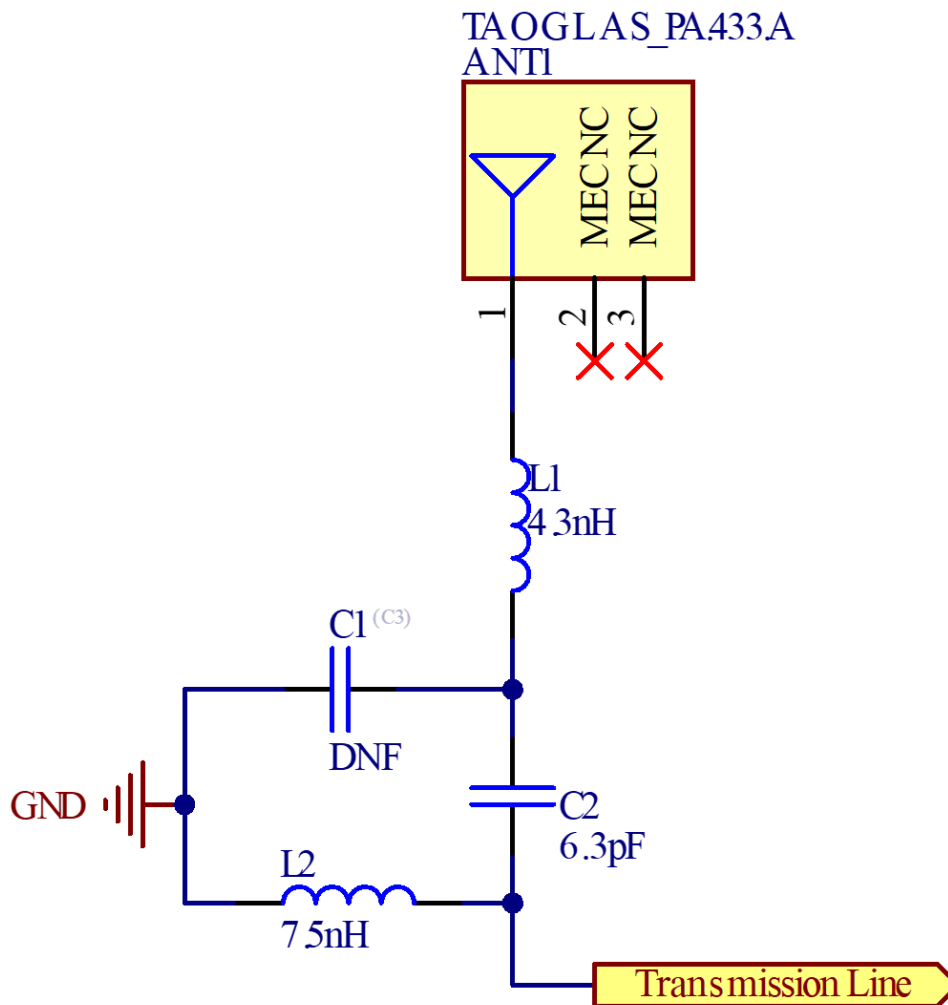

| Designator | Type | Value | Manufacturer | Manufacturer Part Number |
|------------|-----------|------------|--------------|--------------------------|
| C1 | Capacitor | Not Fitted | - | - |
| C2 | Capacitor | 6.3pF | Murata | GJM1555C1H6R3BB01D |
| L1 | Inductor | 4.3nH | TDK | MHQ1005P4N3CT000 |
| L2 | Inductor | 7.5nH | TDK | MLG1005S7N5HT000 |

4.4 Footprint

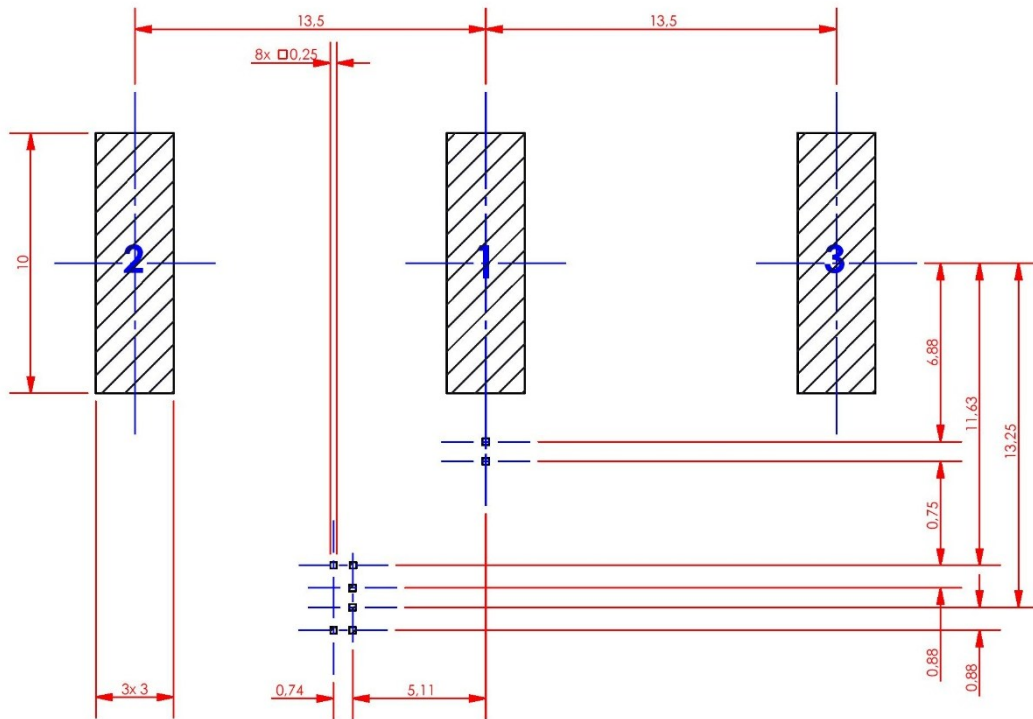

FOOTPRINT PCB

4.5 Top Solder Mask

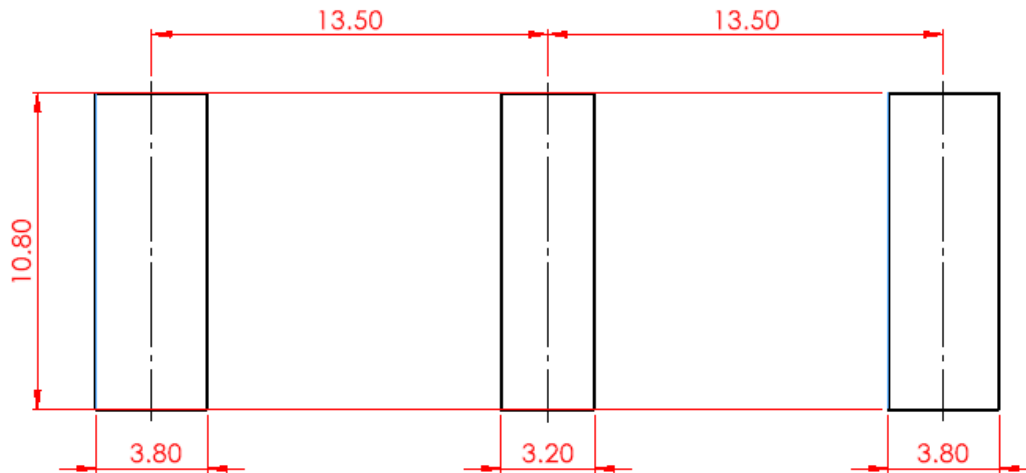

4.6 Top Solder Paste

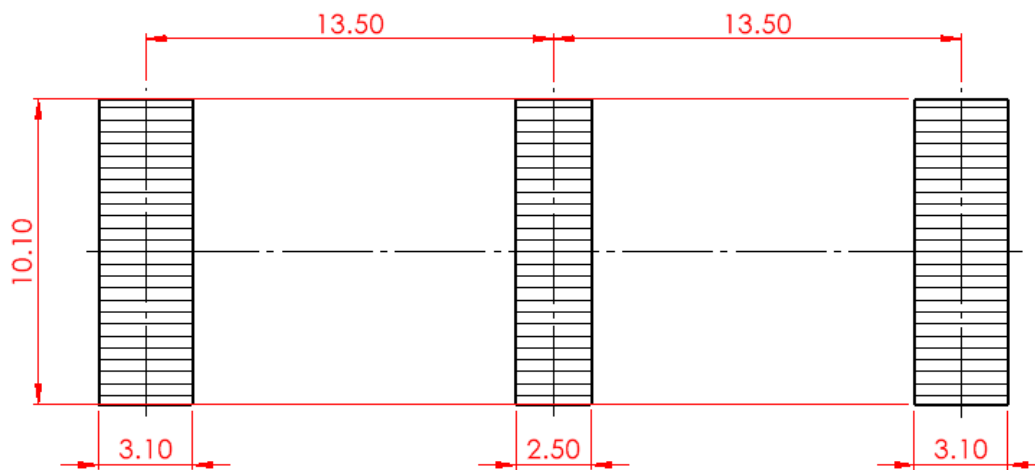

4.7 Copper Clearance for PA.433.A

The footprint and clearance on the PCB must comply with the antenna's specification. The PCB layout shown in the diagrams below demonstrates the PA.433.A clearance area. The copper keep out area applies to all layers that are below the PA.433.A.

The copper clearance area should extend to 6mm from the mechanical pads to the ground plane. The PCB edge clearance should be 0.3 mm.

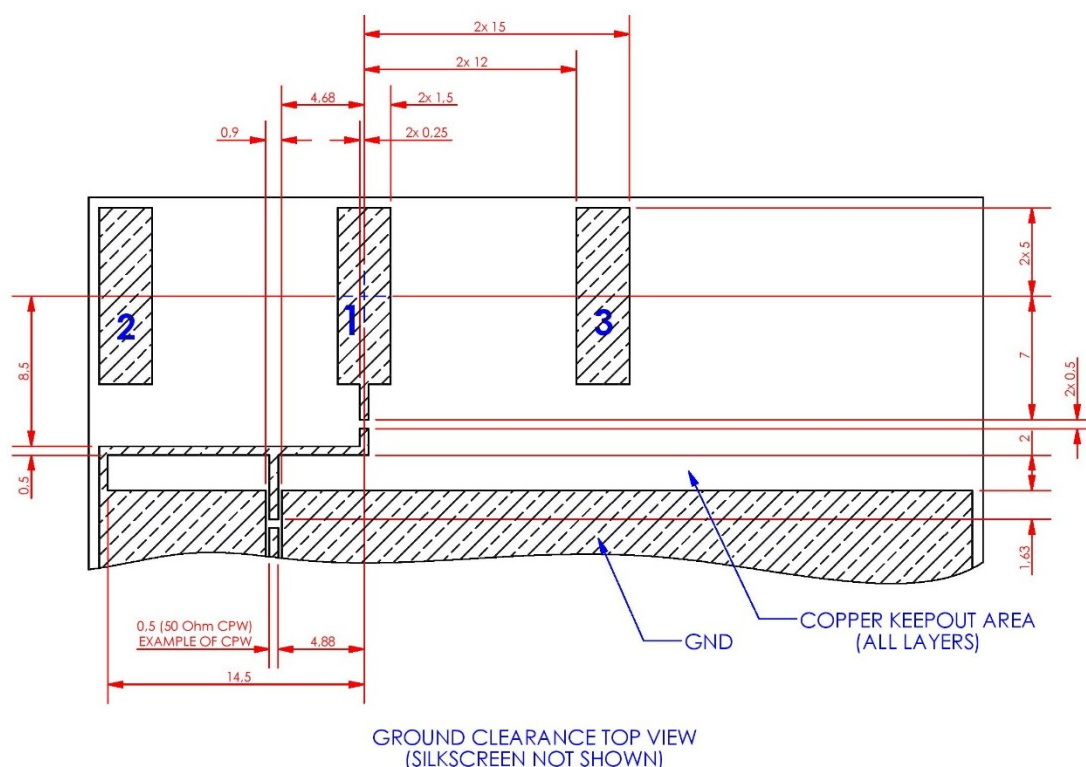

4.8 Antenna Integration

The PA.433.A should be placed in the centre, as close to the edge on the long side of the PCB as possible, to take advantage of the ground plane. The RF trace must maintain a 50 Ohm transmission line. A “pi” Matching Network is recommended for the RF transmission line, the values and components for the matching circuit will depend on the tuning needed. Ground vias should be placed around the transmission line and the copper clearance area.

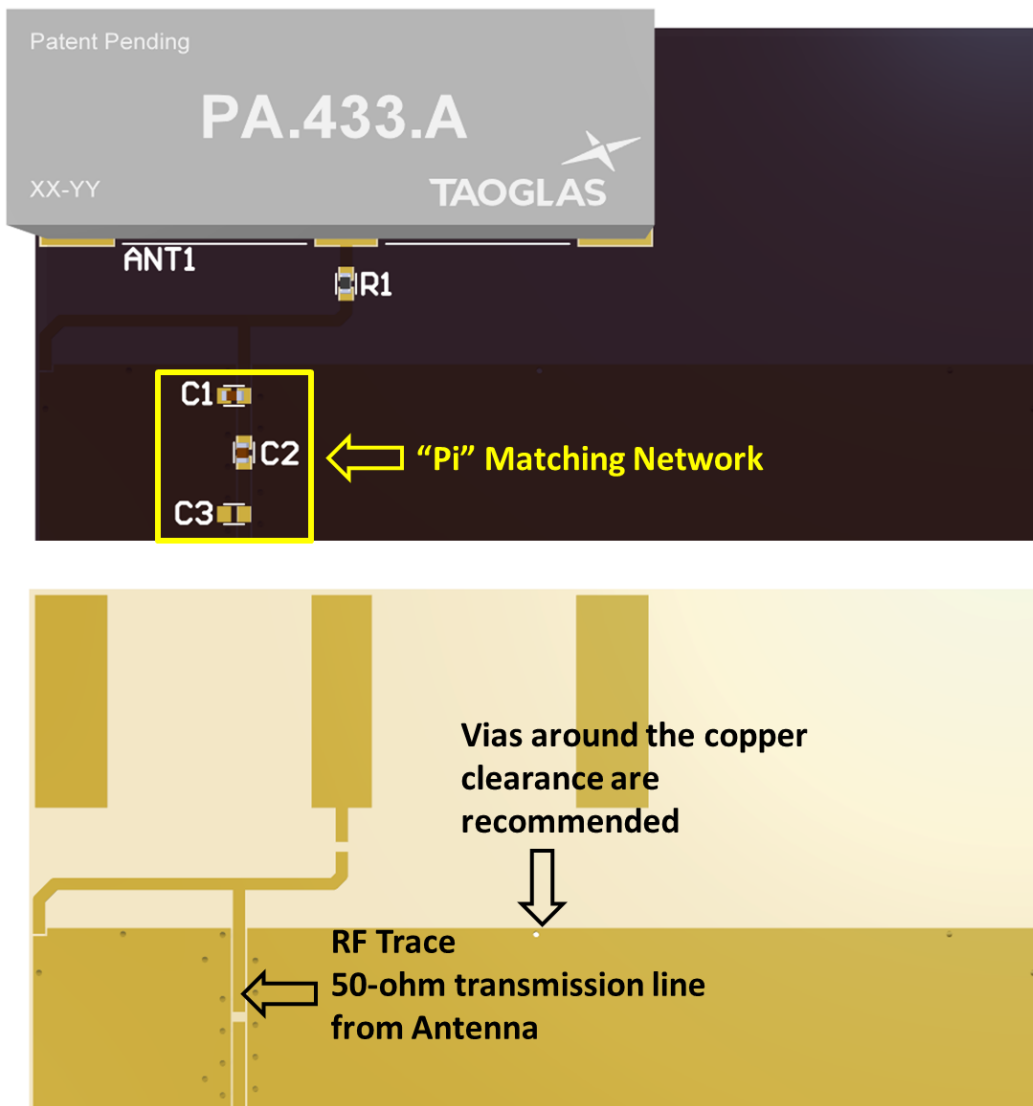

PA.433.A antenna mounted on a PCB reference design, showing the transmission line and integration notes .

4.9 Final Integration

The top side image shown below highlights the antenna transmission line. Taoglas recommends using a minimum of 149 x 50 mm ground plane (PCB) to ensure optimal performance.

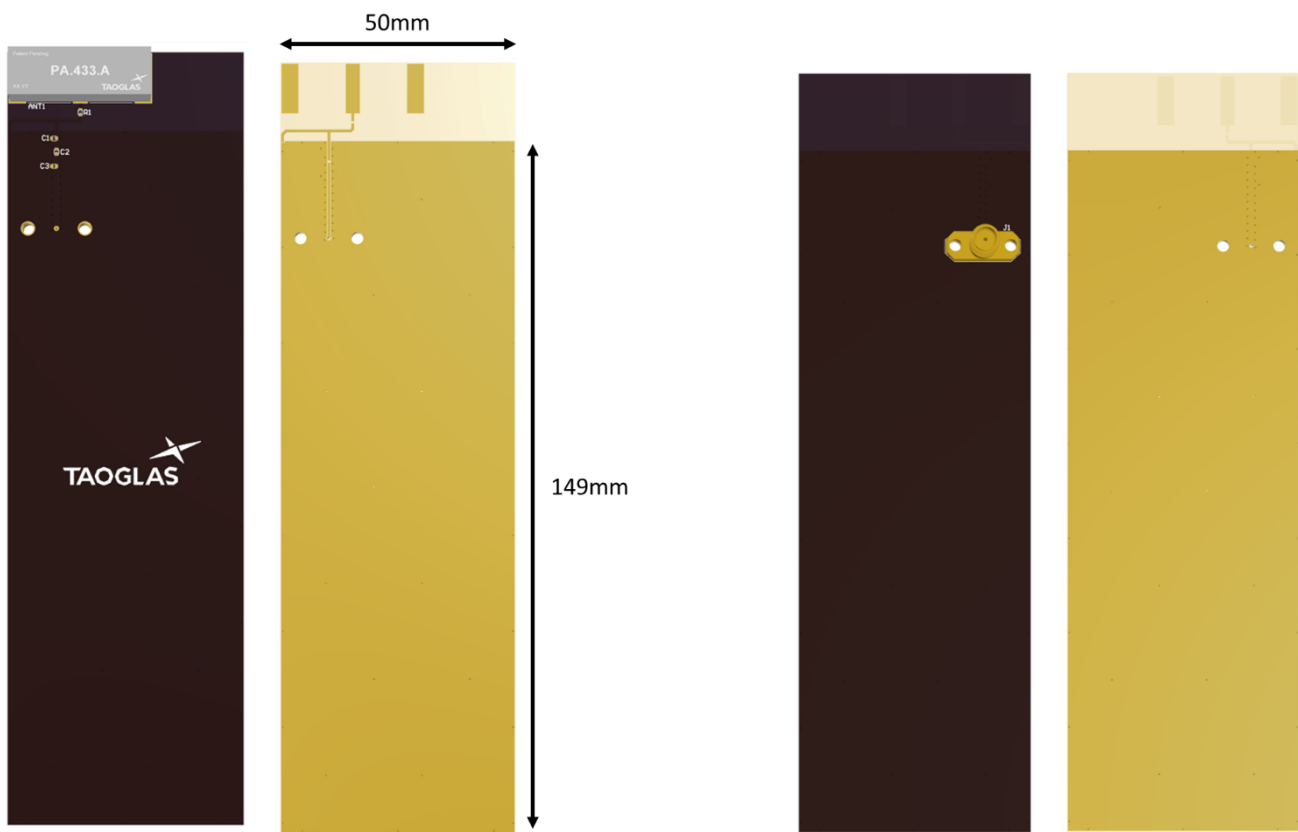

Top Side (PA.433.A placement on 149 x 50 mm PCB reference design)

Bottom Side

5. Packaging

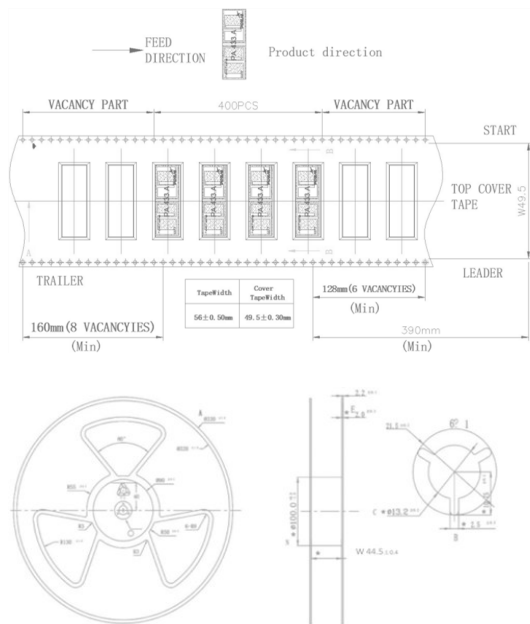

- 400 PCS / Tape & Reel
- 2 PCS / 3g Desiccant
- 1 PCS / Humidity test paper
- SPQ Label



- 400 PCS / Vacuum bag
- MSID Label
- Caution Label
- SPQ Label

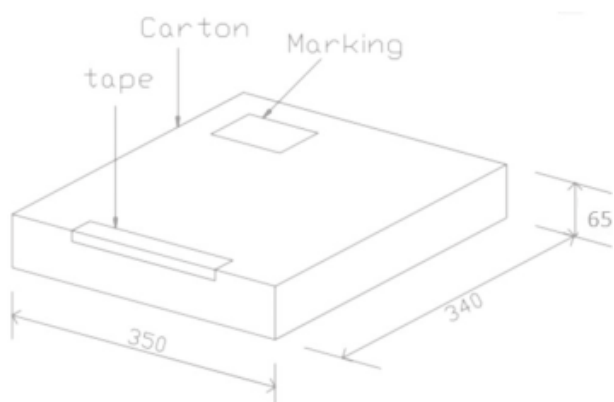

- 400 PCS / Box
- Box(mm): 350 x 340 x 65 mm
- Weight (Kg): 3.2 ± 3%
- SPQ Label

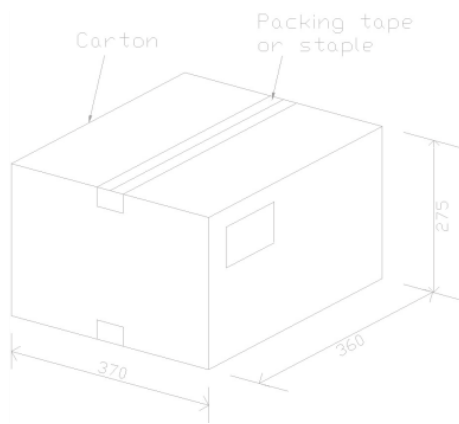

- ☑ 1600 PCS / Carton
- ☑ Carton(mm): 370 x 360 x 275 mm
- ☑ Weight (Kg): 13.7 ±3%
- ☑ Carton Label

6. Antenna Characteristics

6.1 Test Setup

AUT



Vector Network Analyzer



VNA Test Set-up

6.2 Return Loss – 433MHz Tuning Configuration

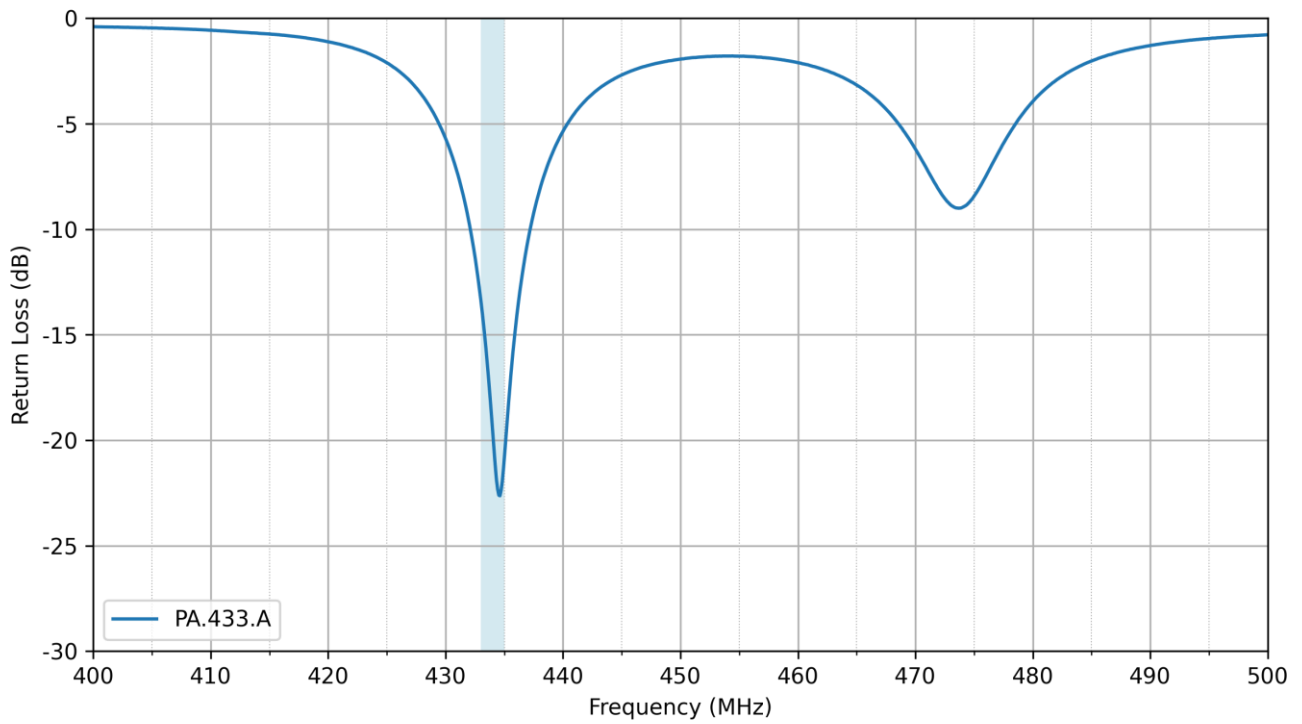

6.3 VSWR – 433MHz Tuning Configuration

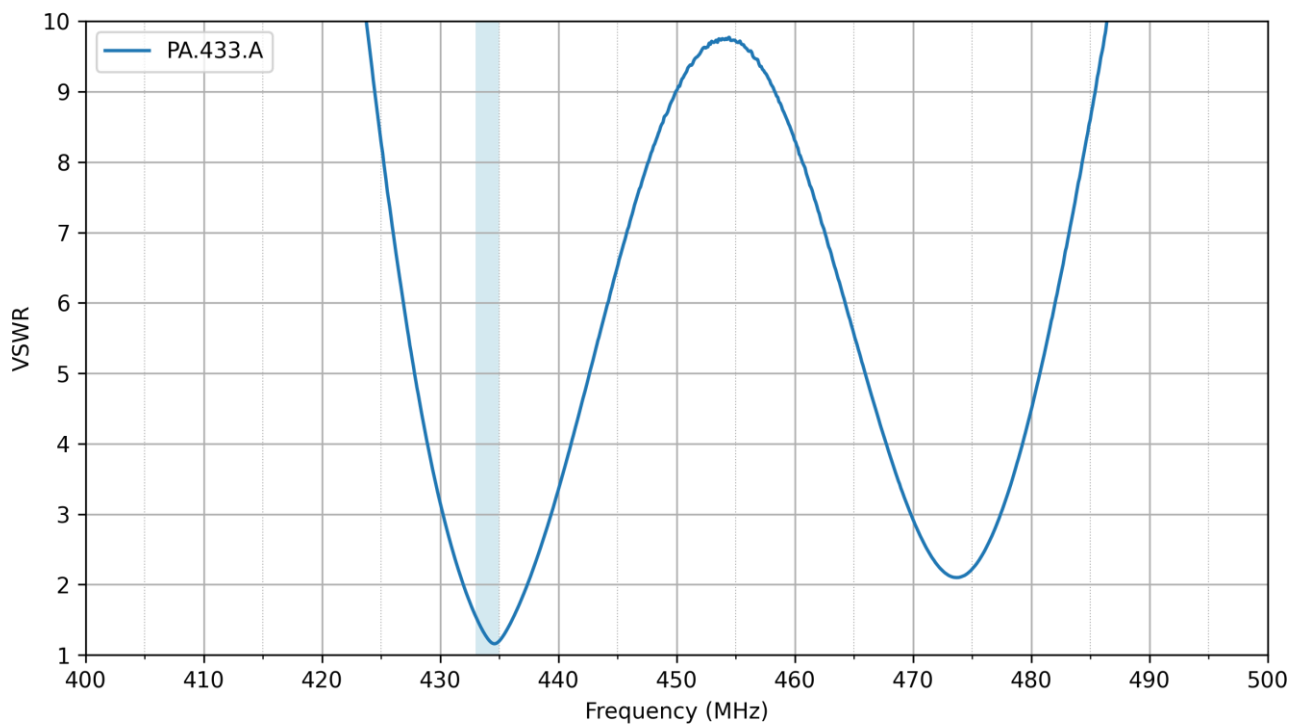

6.4 Efficiency – 433MHz Tuning Configuration

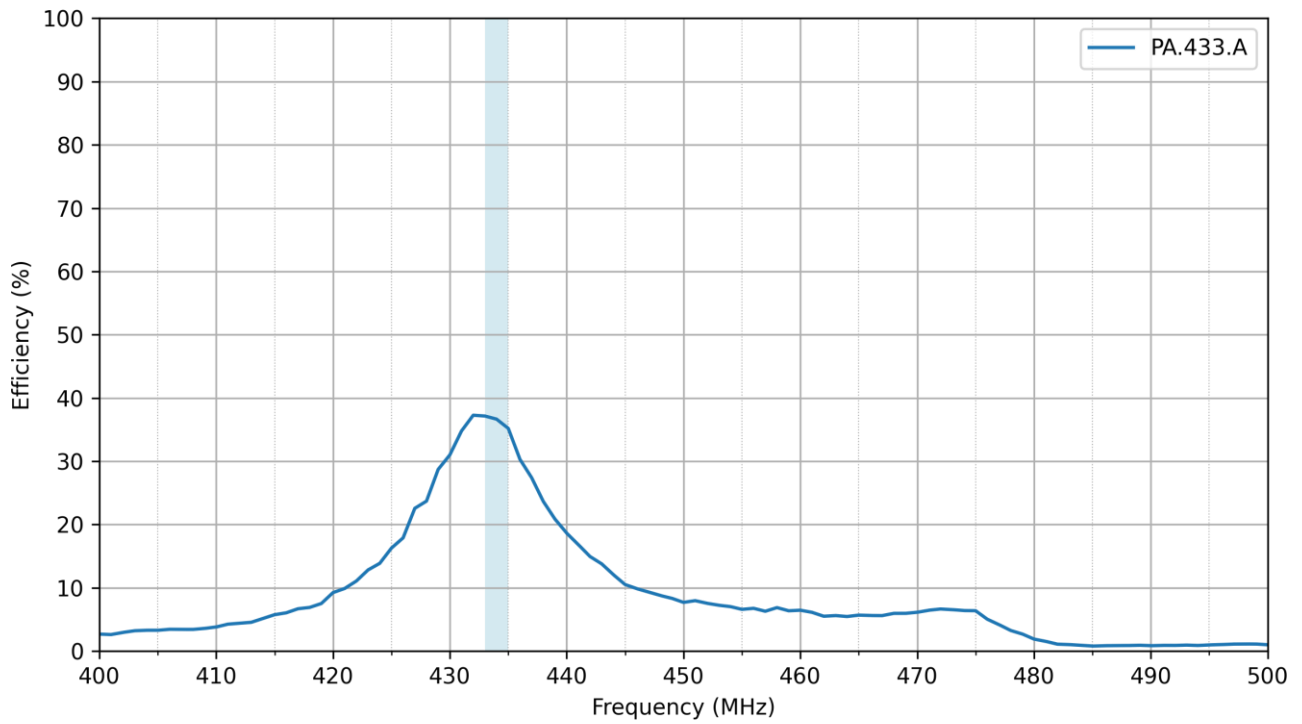

6.5 Average Gain – 433MHz Tuning Configuration

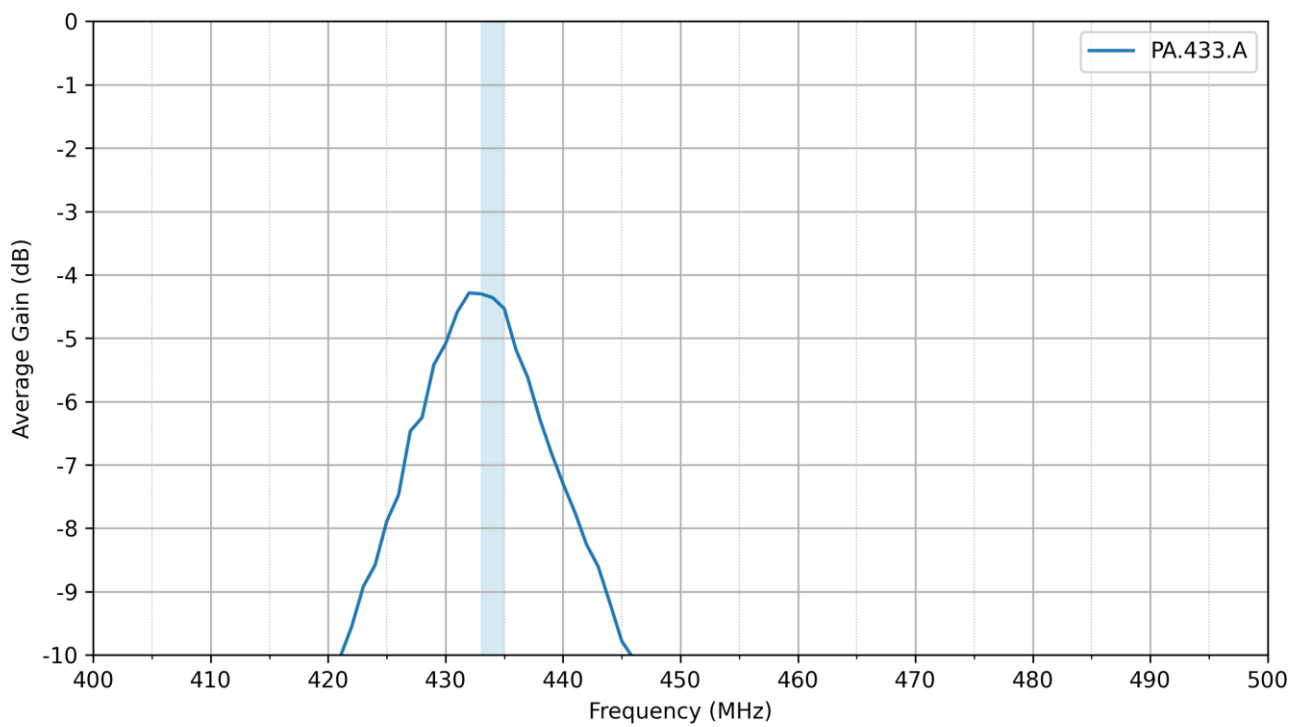

6.6 Peak Gain – 433MHz Tuning Configuration

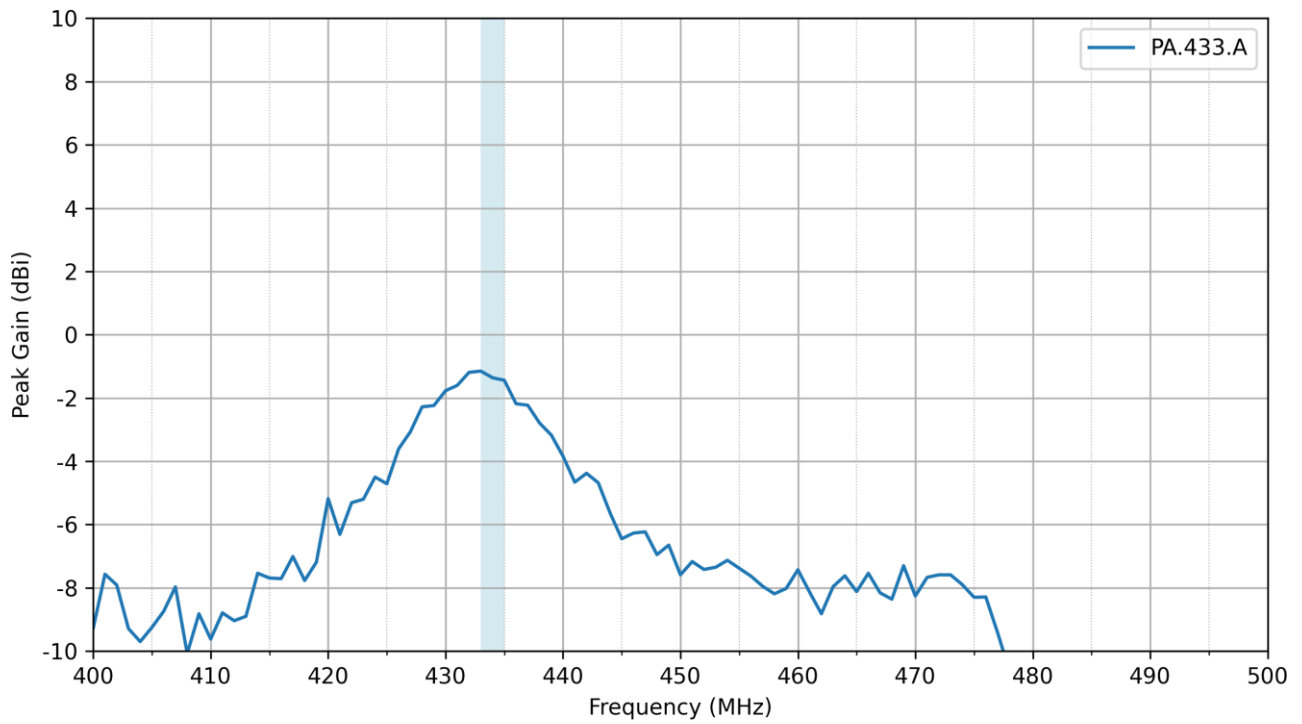

6.7 Return Loss – 433/868/915MHz Tuning Configuration

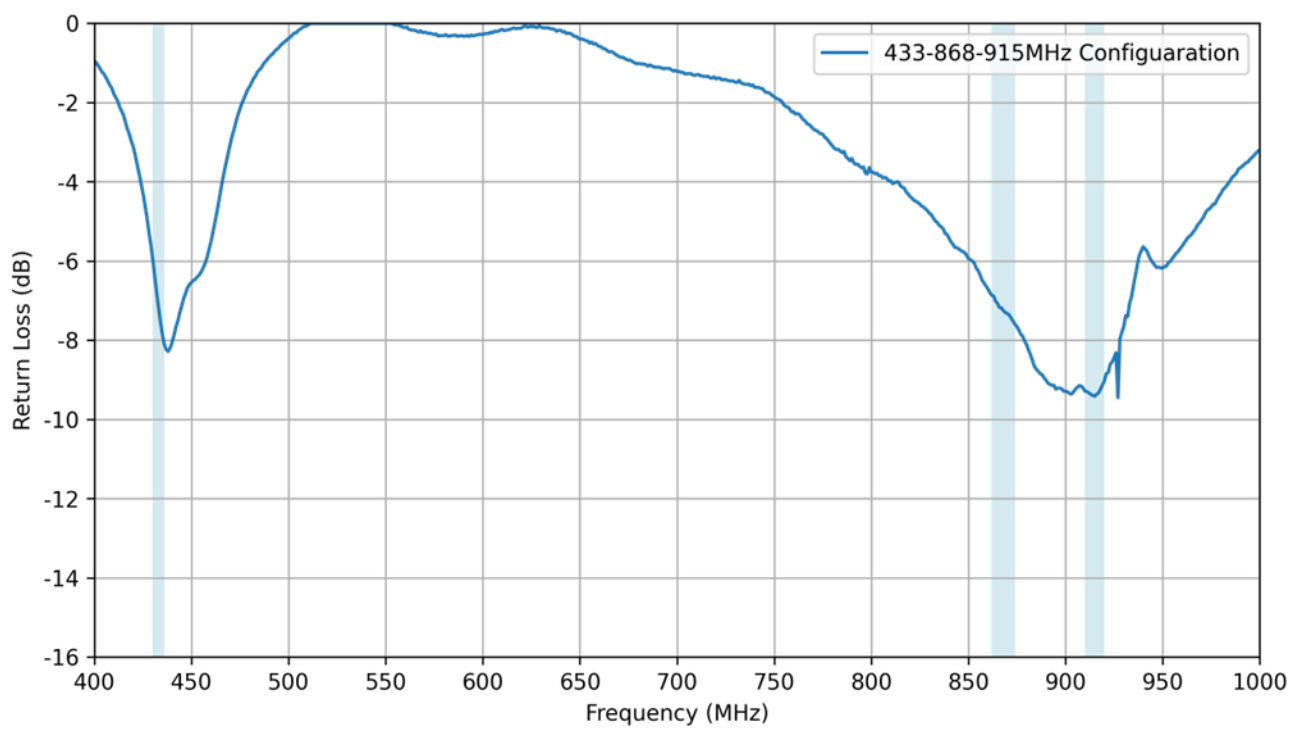

6.8 VSWR – 433/868/915MHz Tuning Configuration

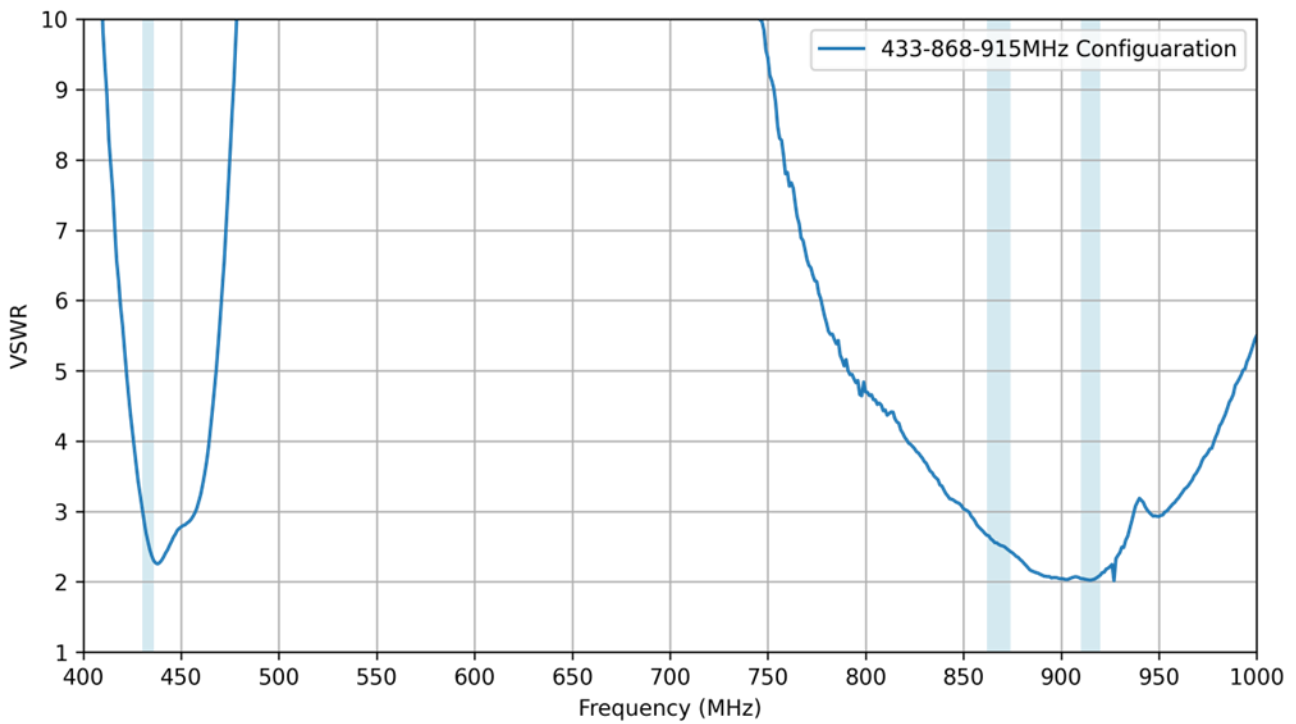

6.9 Efficiency – 433/868/915MHz Tuning Configuration

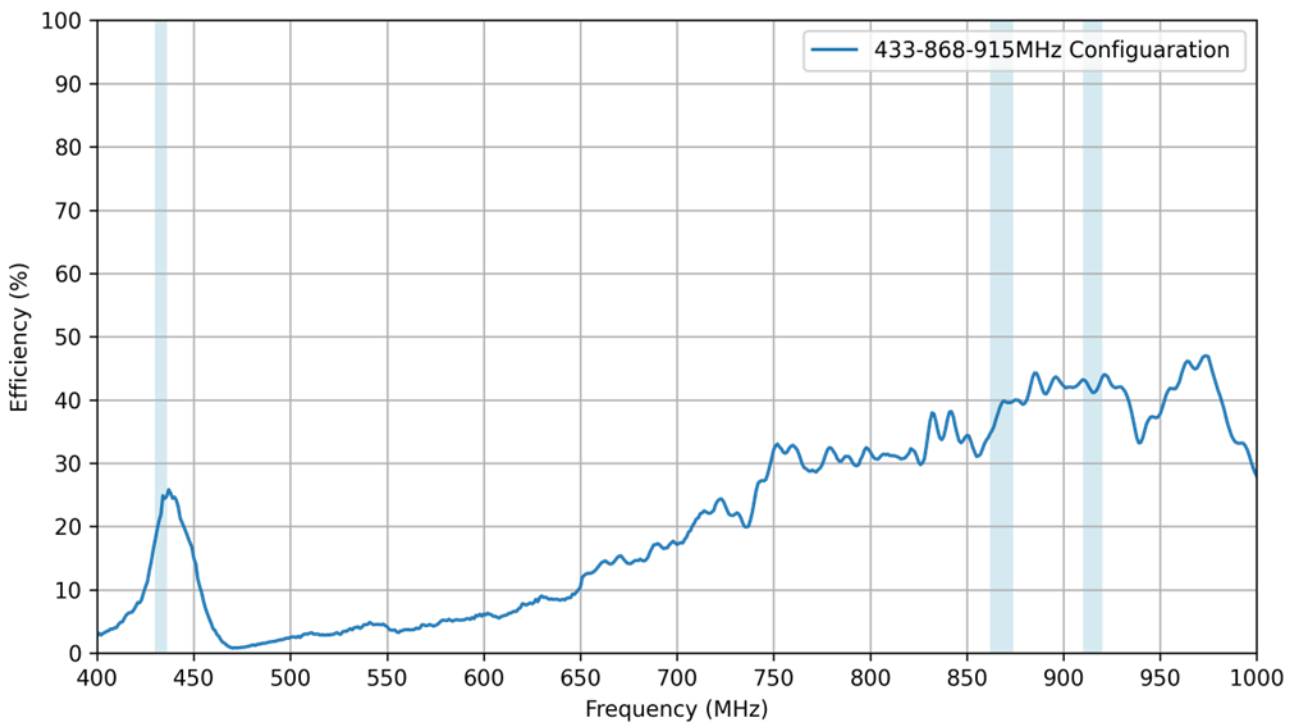

6.10 Average Gain – 433/868/915MHz Tuning Configuration

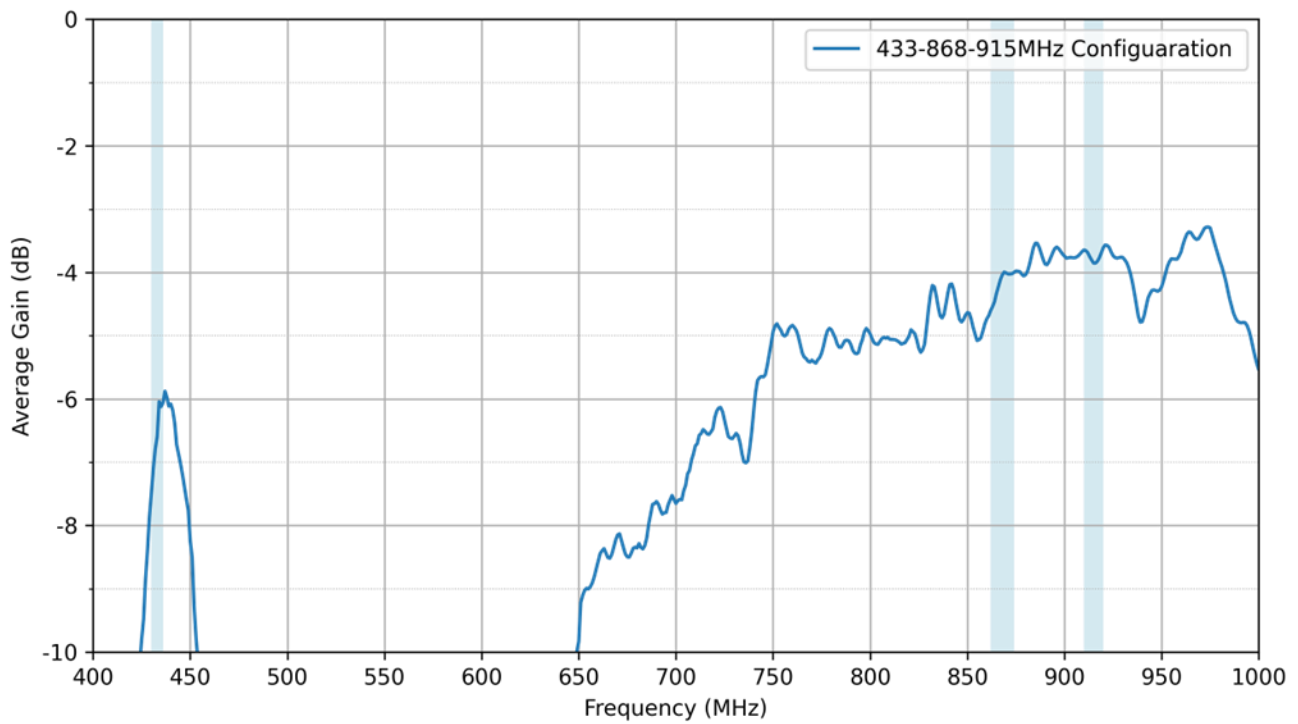

6.11 Peak Gain – 433/868/915MHz Tuning Configuration

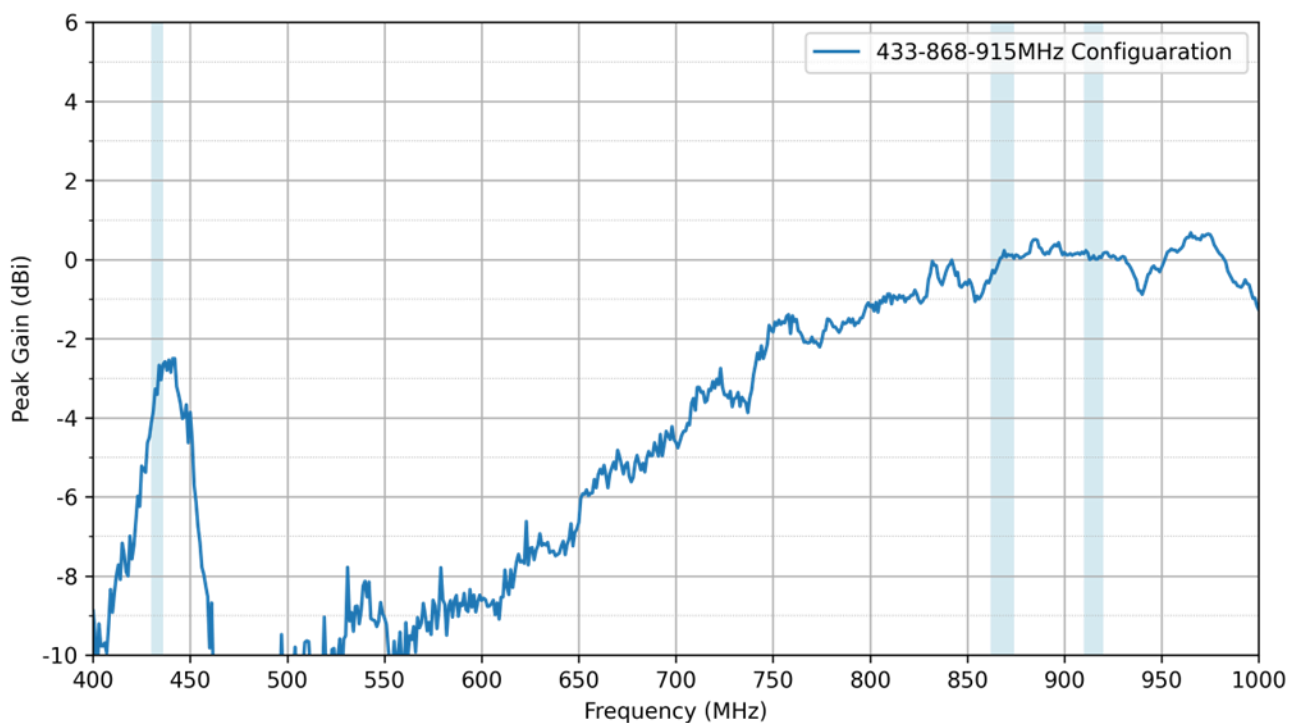

7. Radiation Patterns

7.1 Test Setup

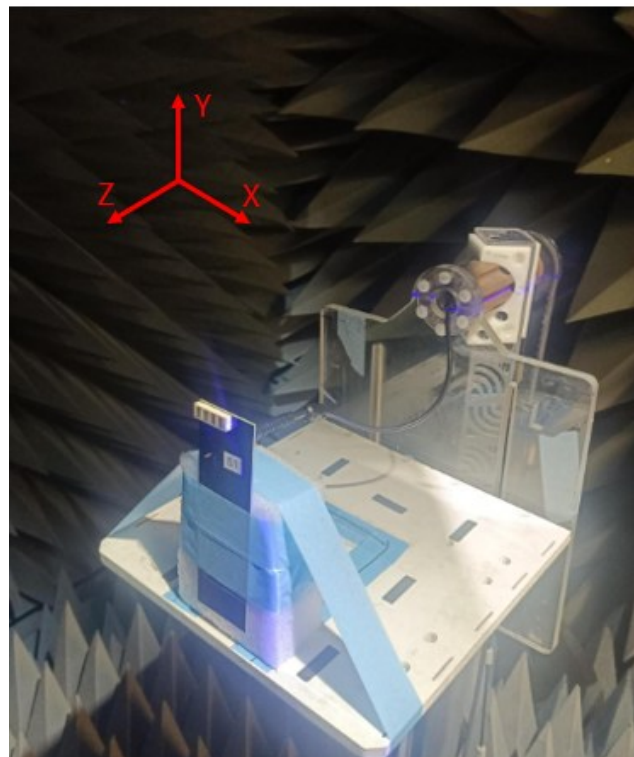
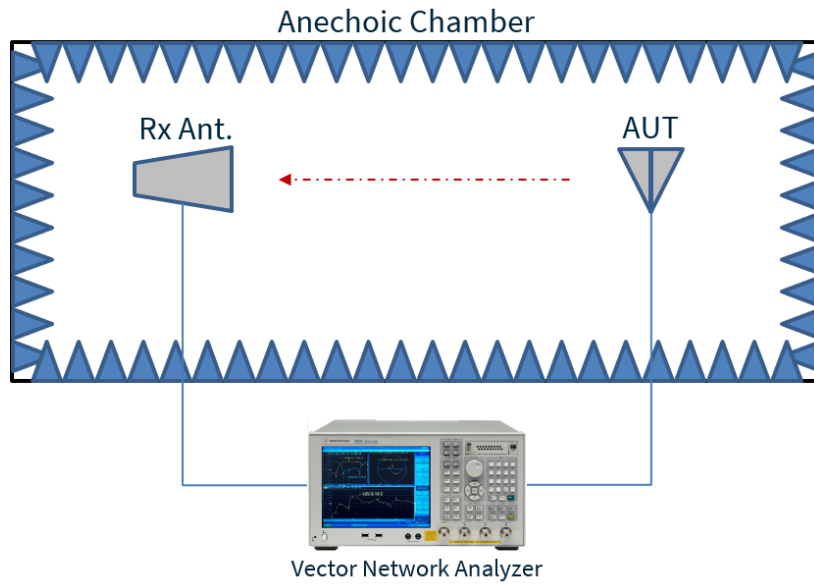

Chamber Test Set-up

7.2 433MHz Configuration Patterns at 434 MHz

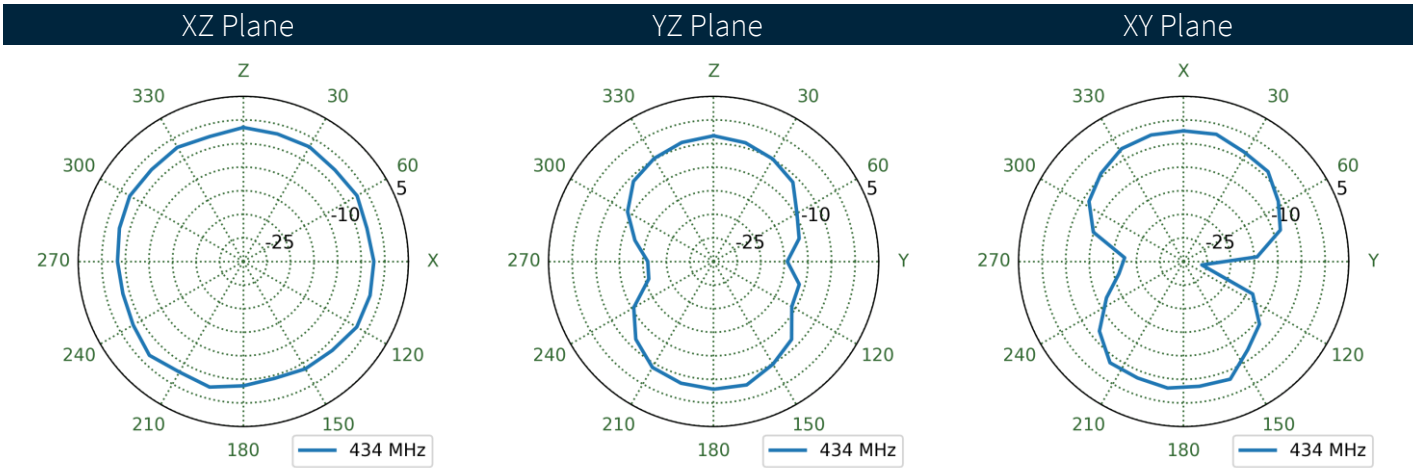
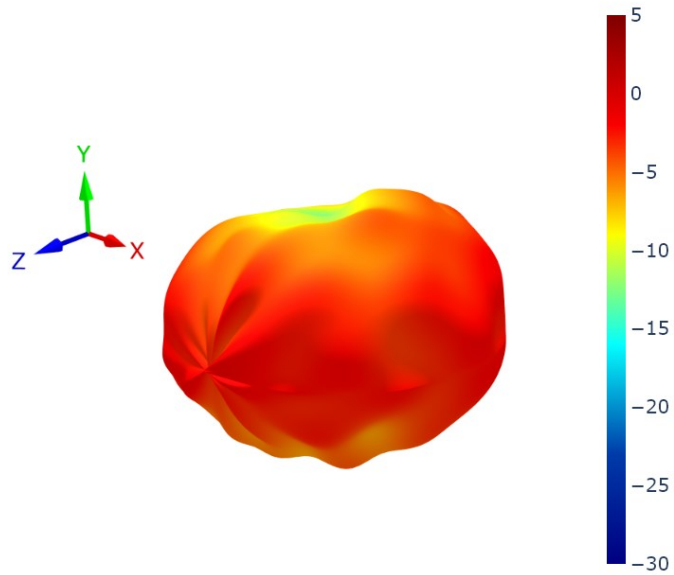

7.3 433-868-915MHz Configuration Patterns at 433 MHz

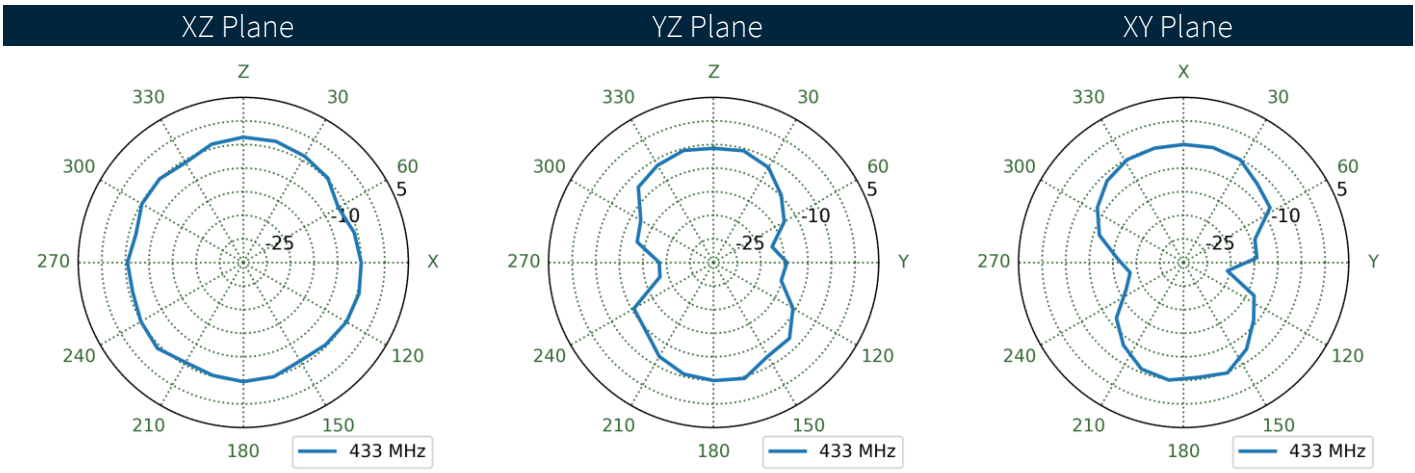
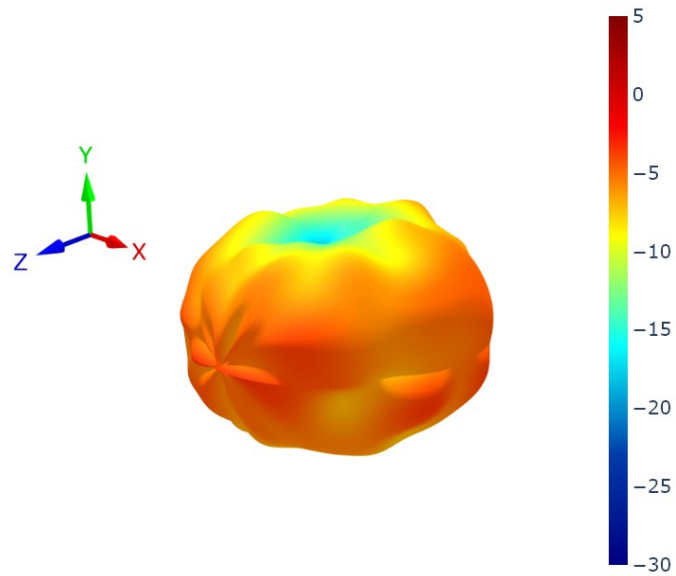

7.4 433-868-915MHz Configuration Patterns at 868 MHz

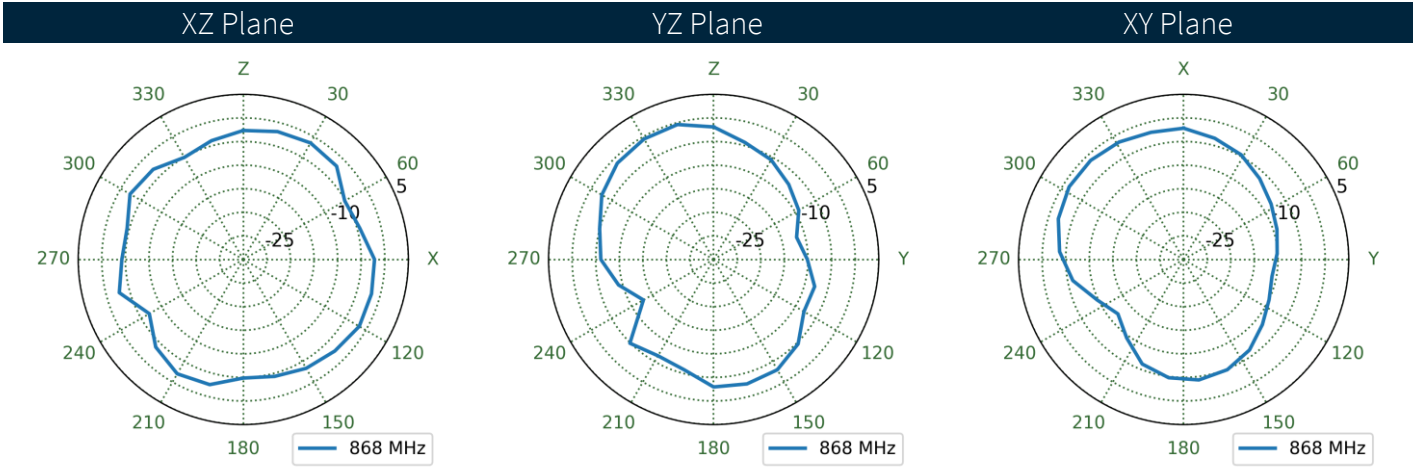
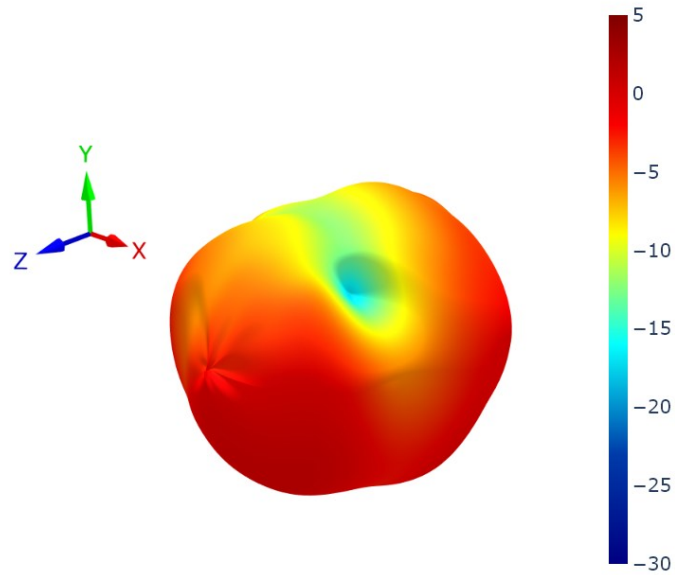

7.5 433-868-915MHz Configuration Patterns at 915 MHz

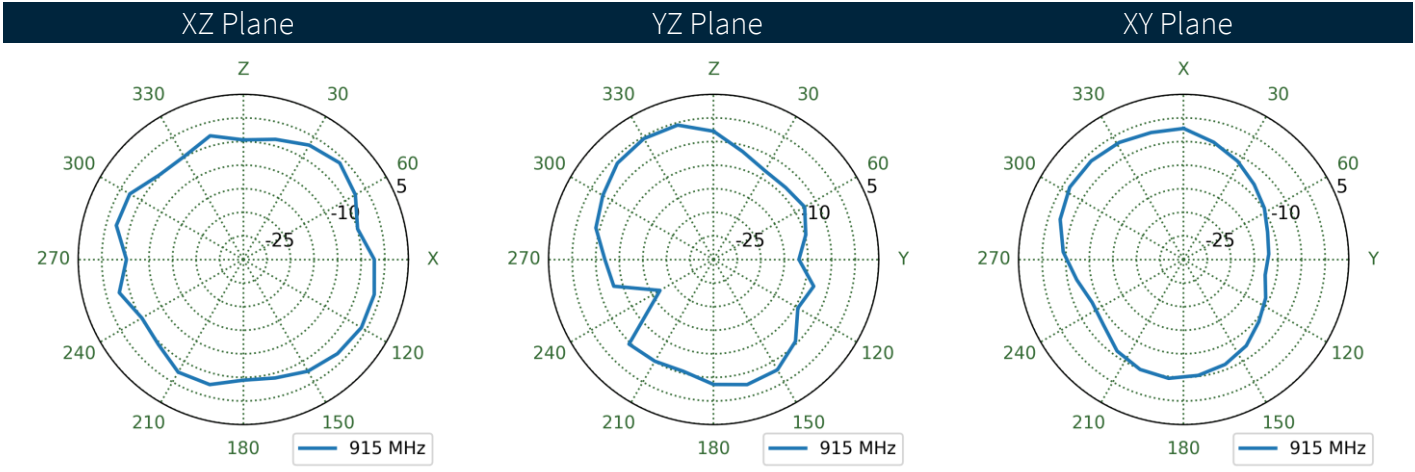
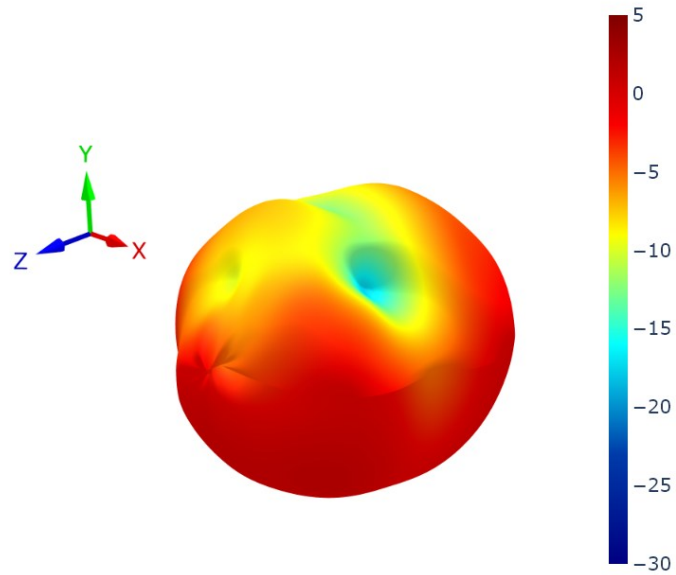

8. Application Note – Copper Clearance

The following illustrates how copper clearance affects antenna performance. In the example below, copper is added at distances of 5 mm, 10 mm, and 15 mm from the antenna.

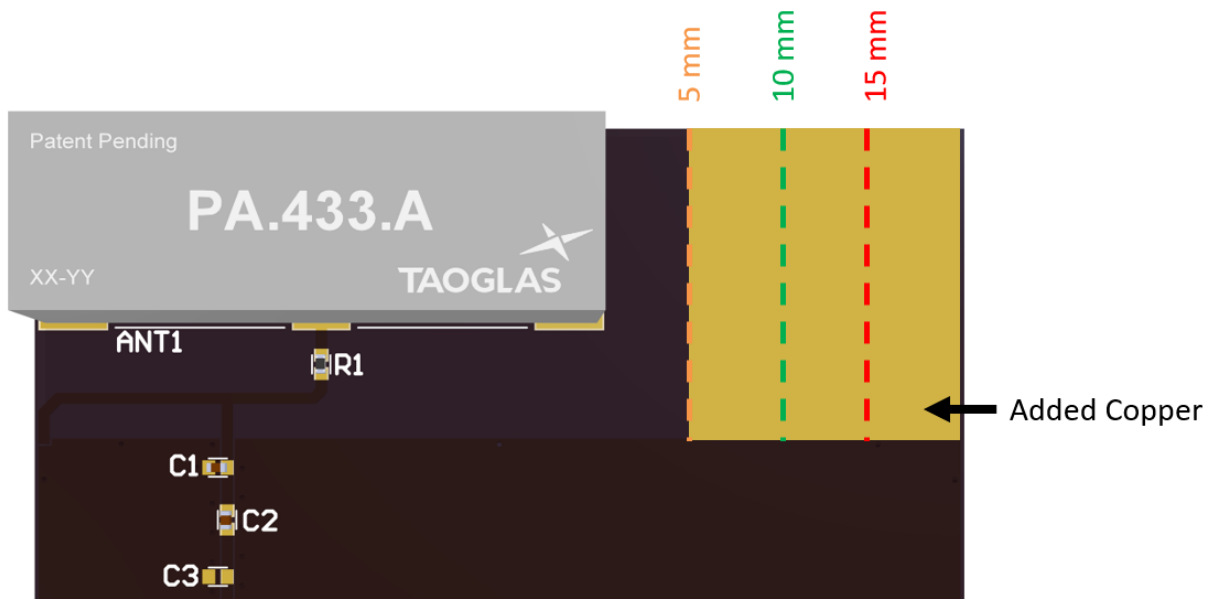

8.1 Return Loss

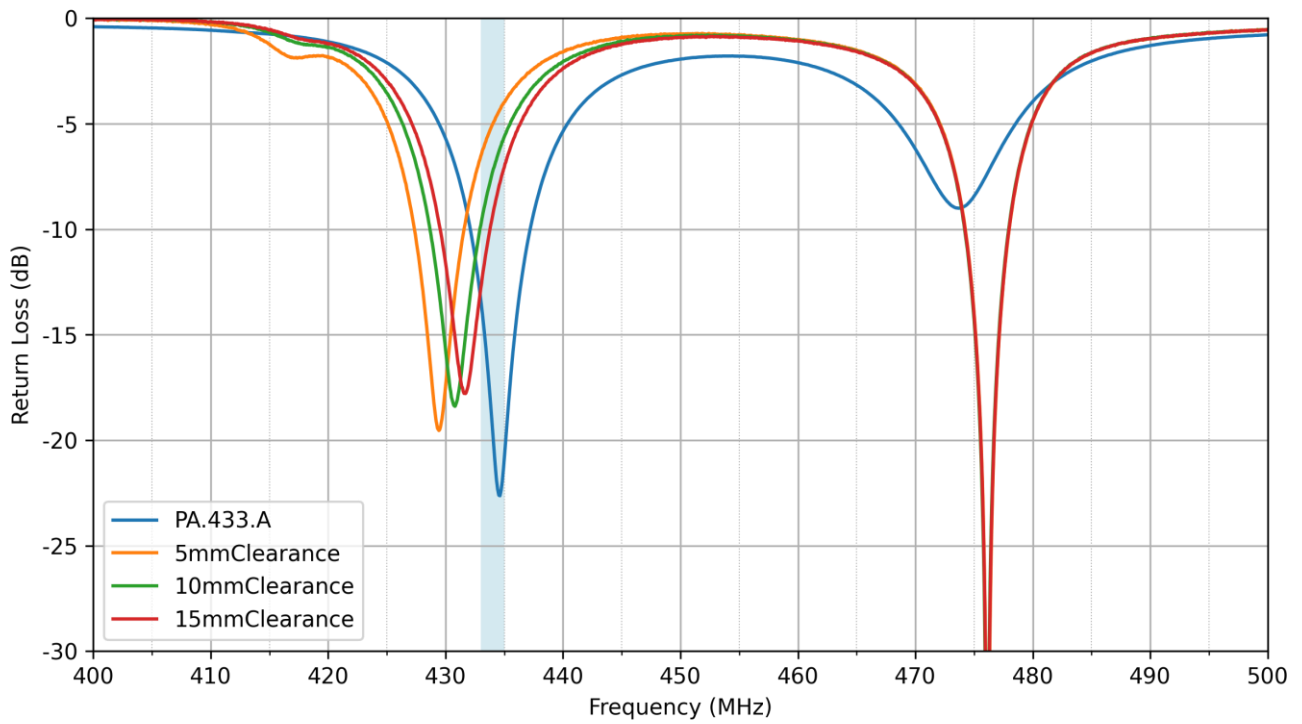

8.2 VSWR

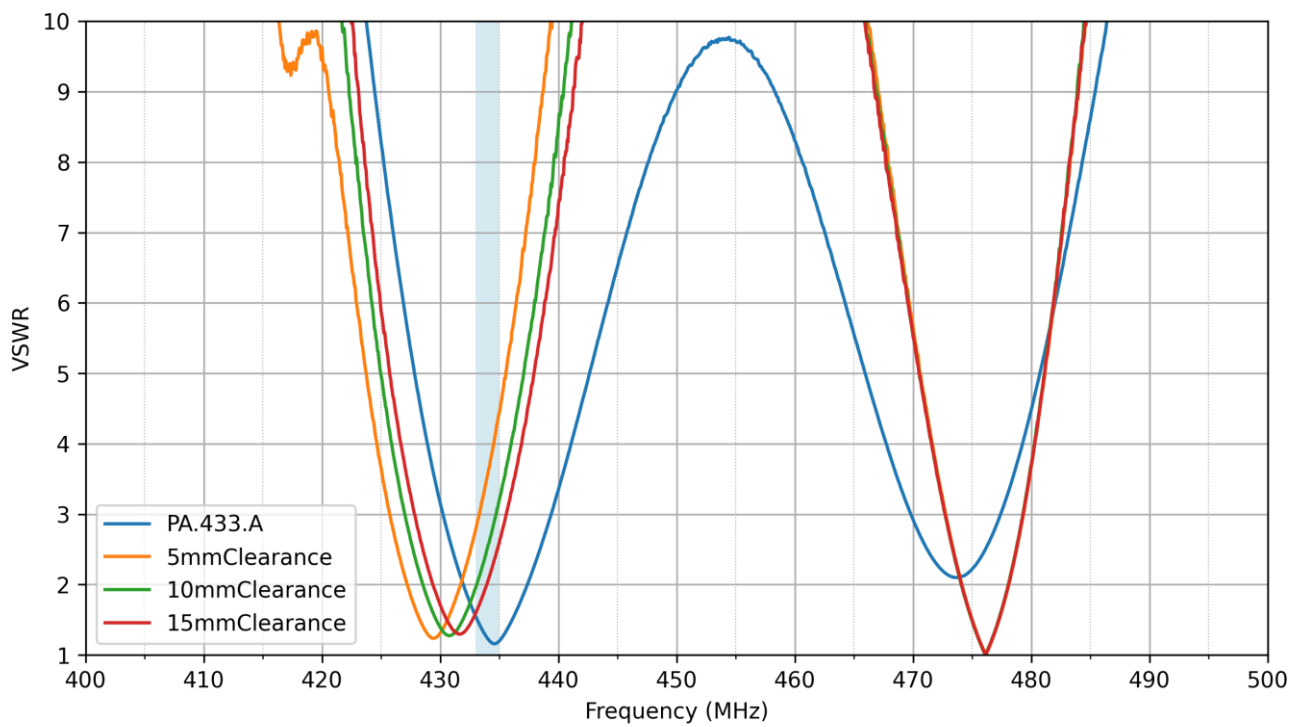

8.3 Efficiency

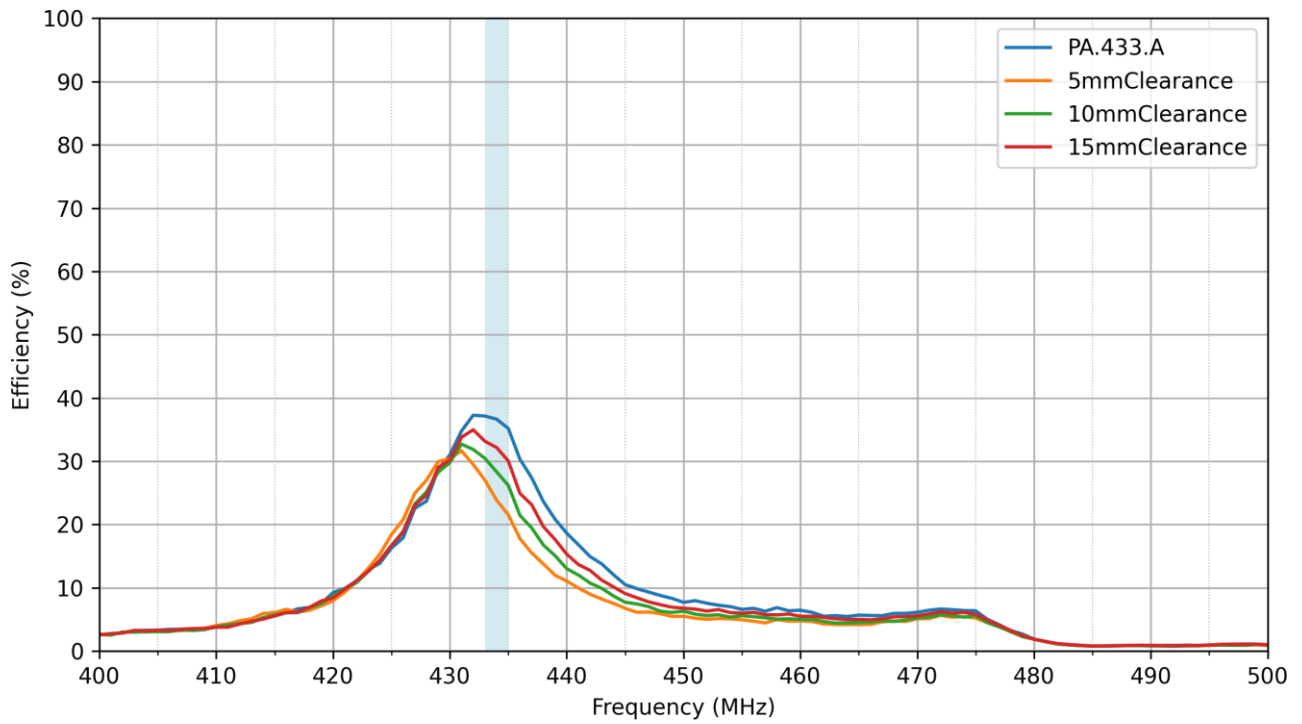

8.4 Average Gain

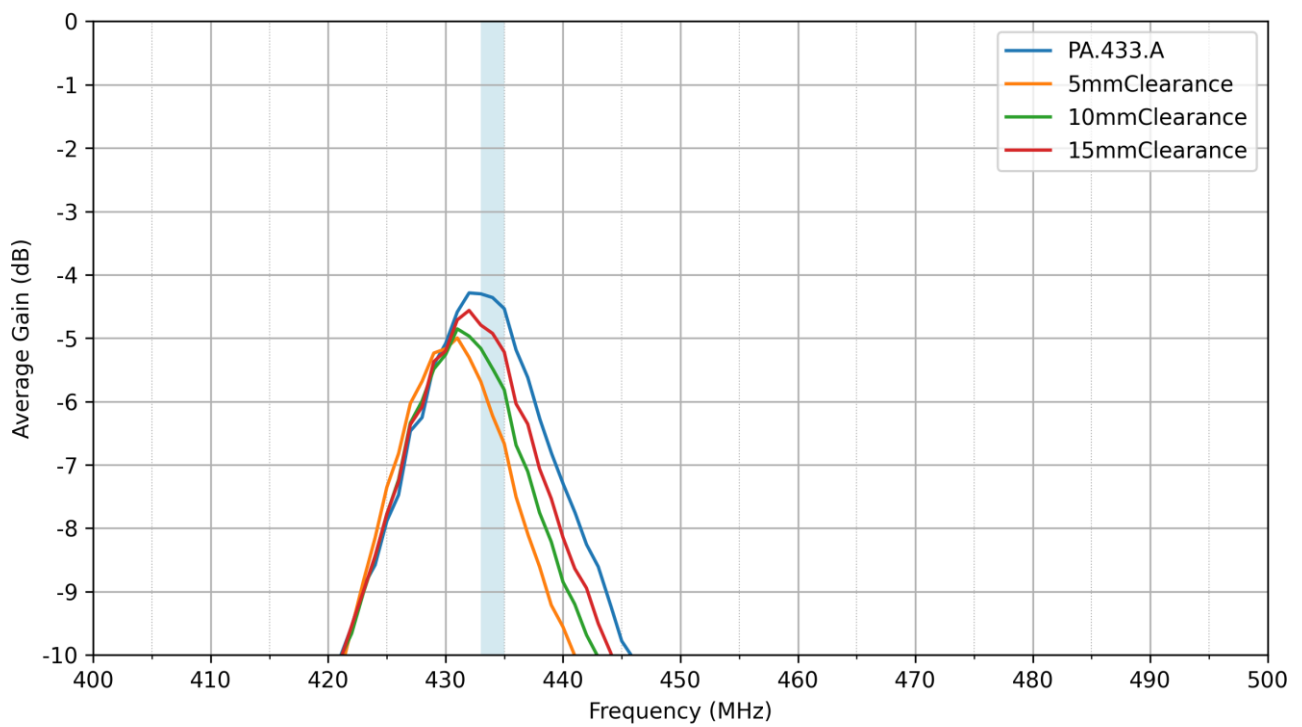

8.5 Peak Gain

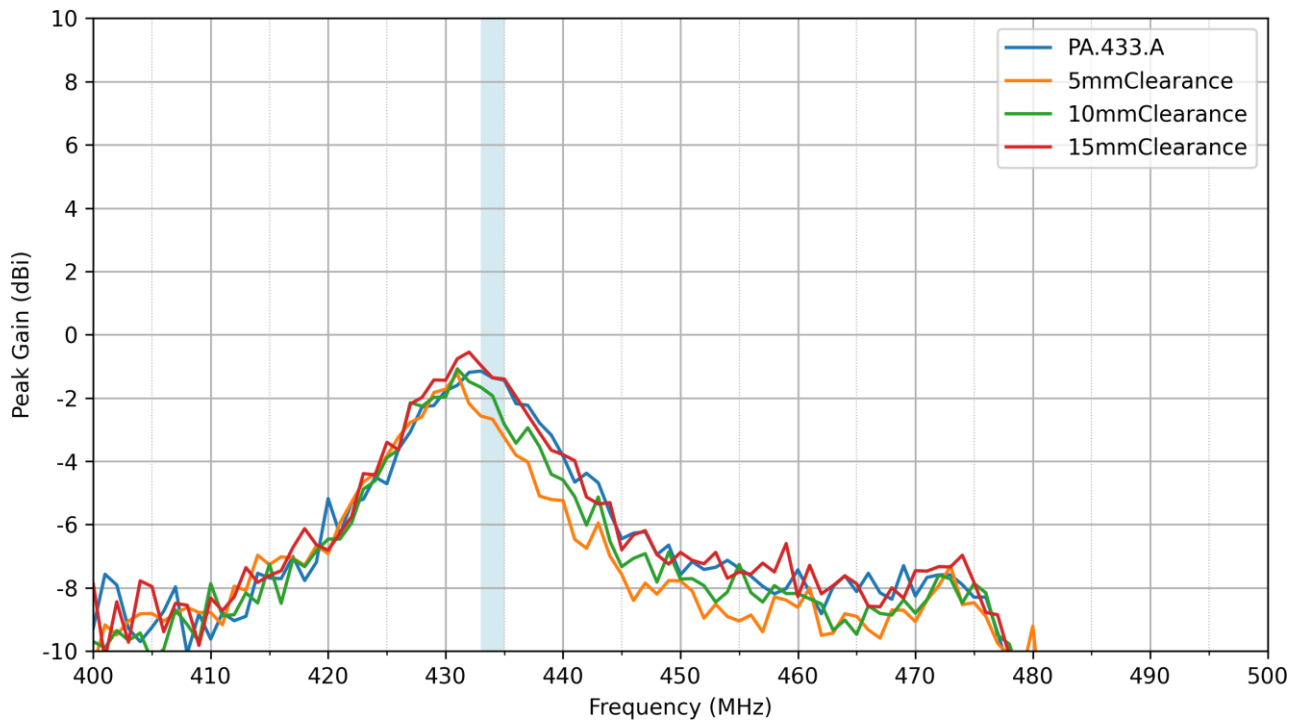

Changelog for the datasheet

SPE-25-8-258 – PA.433.A

Revision: D (Current Version)

Date: 2026-05-20

Notes: Added Multi-Band Configuration.

Author: Gary West

Previous Revisions

Revision: C

Date: 2026-04-29

Notes: Updated temperature range to fit AEC-Q200.

Author: Paul Liu

Revision: B

Date: 2026-02-23

Notes: Updated product image.

Author: Conor McGrath

Revision: A (Original First Release)

Date: 2025-09-19

Notes: Initial Release

Author: Gary West



www.taoglas.com

