

# Remote I/O Boxes (EtherNet/IP)



## ADIO-EI PRODUCT MANUAL

For your safety, read and follow the considerations written in the instruction manual, other manuals and Autonics website.

The specifications, dimensions, etc. are subject to change without notice for product improvement. Some models may be discontinued without notice.

### Features

- The upper level communication protocol: EtherNet/IP
- The lower level communication protocol: IO-Link ver. 1.1 (port class: Class A)
- Housing material: Zinc Die casting
- Protection rating: IP67
- The daisy chain allows the power supply using the connection technology in a standardized 7/8" connector
- The maximum output current of power supply: 2 A per port
- I/O port settings and status monitoring (cable short / disconnection, connection status, etc.)
- Supports digital input filter

### Safety Considerations

- Observe all 'Safety Considerations' for safe and proper operation to avoid hazards.
- ⚠ symbol indicates caution due to special circumstances in which hazards may occur.

**⚠ Warning** Failure to follow instructions may result in serious injury or death.

- 01. Fail-safe device must be installed when using the unit with machinery that may cause serious injury or substantial economic loss. (e.g. nuclear power control, medical equipment, ships, vehicles, railways, aircraft, combustion apparatus, safety equipment, crime/disaster prevention devices, etc.)**  
Failure to follow this instruction may result in personal injury, economic loss or fire.
- 02. Do not use the unit in the place where flammable/explosive/corrosive gas, high humidity, direct sunlight, radiant heat, vibration, impact or salinity may be present.**  
Failure to follow this instruction may result in explosion or fire.
- 03. Do not connect, repair, or inspect the unit while connected to a power source.**  
Failure to follow this instruction may result in fire.
- 04. Check 'Connections' before wiring.**  
Failure to follow this instruction may result in fire.
- 05. Do not disassemble or modify the unit.**  
Failure to follow this instruction may result in fire.
- 06. Do not touch the product during operation or for a certain period of time after stopping.**  
Failure to follow this instruction may result in burn.

**⚠ Caution** Failure to follow instructions may result in injury or product damage.

- 01. Use the unit within the rated specifications.**  
Failure to follow this instruction may result in fire or shortening the life cycle of the product.
- 02. Use a dry cloth to clean the unit, and do not use water or organic solvent.**  
Failure to follow this instruction may result in fire.
- 03. Keep the product away from metal chip, dust, and wire residue which flow into the unit.**  
Failure to follow this instruction may result in fire or product damage.
- 04. Connect the cable correctly and prevent poor contact.**  
Failure to follow this instruction may result in fire or product damage.
- 05. Do not connect or cut off the wire of the cable while operating the unit.**  
Failure to follow this instruction may result in fire or product damage.

### Cautions during Use

- Follow instructions in 'Cautions during Use'. Otherwise, it may cause unexpected accidents.
- The UA power (actuator power) and US power (sensor power) should be insulated by the individually isolated power device.
- Power supply should be insulated and limited voltage/current or Class 2, SELV power supply device.
- Use the rated standard cables and connectors. Do not apply excessive power when connecting or disconnecting the connectors of the product.
- Keep away from high voltage lines or power lines to prevent inductive noise. In case installing power line and input signal line closely, use line filter or varistor at power line and shielded wire at input signal line. For stable operation, use shield wire and ferrite core, when wiring communication wire, power wire, or signal wire.
- Do not use near the equipment which generates strong magnetic force or high frequency noise.
- Do not connect, or remove this unit while connected to a power source.
- This unit may be used in the following environments.
  - Indoors (in the environment condition rated in 'Specifications')
  - Altitude max. 2,000 m
  - Pollution degree 2
  - Installation category II

## Configuration of ADIO-EI

The figure below shows the EtherNet/IP network and the devices that compose it.

For proper use of the product, refer to the manuals and be sure to follow the safety considerations in the manuals.

Download the manuals from the Autonics website.

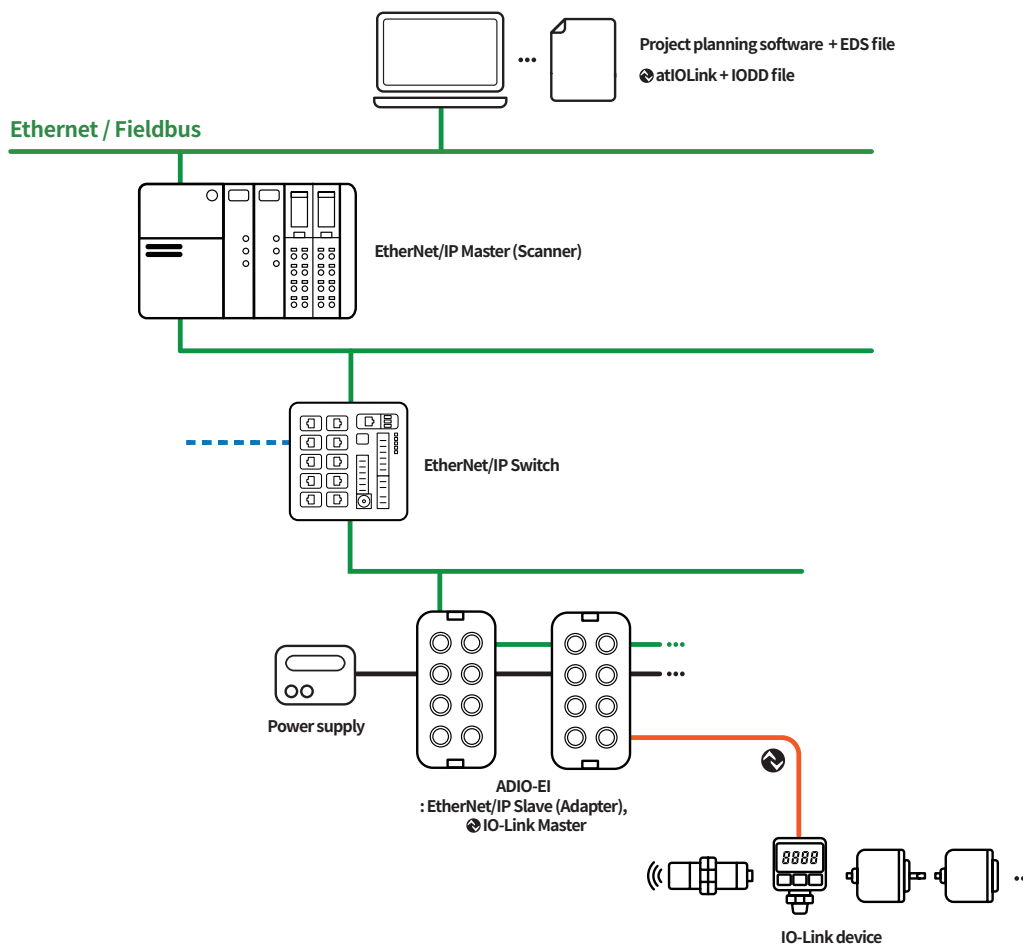

STEP		Reference manual
Hardware installation	Install and ground the ADIO	ADIO-EI Product Manual
	Connect the ports of ADIO	
	Supply power to the ADIO	
IO-Link device settings	Set parameters and functions of IO-Link device	atIOLink User Manual
EtherNet/IP Master ↕ ADIO-EI	Integrate the ADIO-EI to EtherNet/IP project	ADIO-EI (Studio 5000 Logix Designer Guide) <sup>01)</sup>
	Set the ports of ADIO-EI	
Checking the operation	Check the indicators	ADIO-EI Product Manual

01) The project planning software of the upper level communication system may be different depending on the user's environment.

For more information, refer to the manufacturer's manual.

### ■ The configuration instance and class

Operation mode	Fault State <sup>01)</sup>	Validation	Data Storage	Input Filter <sup>01)</sup>	Vendor ID	Device ID	Cycle Time
Digital Input	-	-	-	○	-	-	-
Digital Output	○	-	-	-	-	-	-
IO-Link Input	-	○	○	-	○	○	○
IO-Link Output	-	○	○	-	○	○	○
IO-Link Input/Output	-	○	○	-	○	○	○

01) Unsupported on the atIOLink

## Ordering Information

This is only for reference, the actual product does not support all combinations. For selecting the specified model, follow the Autonics website.

**ADIO - EI - MA 08 A ① - ILM**

### ① I/O specification

N: NPN

P: PNP

## Product Components

- Product (+ Protective cover for the rotary switches)
- Name plates × 20
- M4×10 screw with washer × 1
- Instruction manual × 1
- Waterproof cover × 4

## Sold Separately

- Name plates
- Waterproof cover

## Software

Download the installation file and the manuals from the Autonics website.

### ■ atIOLink

atIOLink with purposes for setting, diagnosis, initialization and maintenance of IO-Link device via IODD file is provided as the dedicated Port and Device Configuration Tool (PDCT).

## Connections

### ■ Ethernet port

M12 (Socket-Female), D-coded	Pin	Function	Description
	1	TX +	Transmit Data +
	2	RX +	Receive Data +
	3	TX -	Transmit Data -
	4	RX -	Receive Data -

### ■ Power supply port

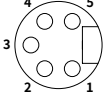
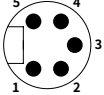
OUT (7/8", Socket-Female)	IN (7/8", Plug-Male)	Pin	Function	Description
		1, 2	0V	Sensor and actuator supply
		3	F.G.	Frame ground
		4	+24 VDC≐	Sensor supply
		5	+24 VDC≐	Actuator supply

### ■ PDCT port

M12 (Socket-Female), A-coded	Pin	Function
	1	Not Connected (N.C.)
	2	Data -
	3	0V
	4	Not Connected (N.C.)
	5	Data +

### ■ I/O port

M12 (Socket-Female), A-coded	Pin	Function
	1	+24 VDC≐
	2	I/Q: Digital Input
	3	0V
	4	C/Q: IO-Link, Digital Input/Output
	5	Not Connected (N.C.)



## Unit Descriptions

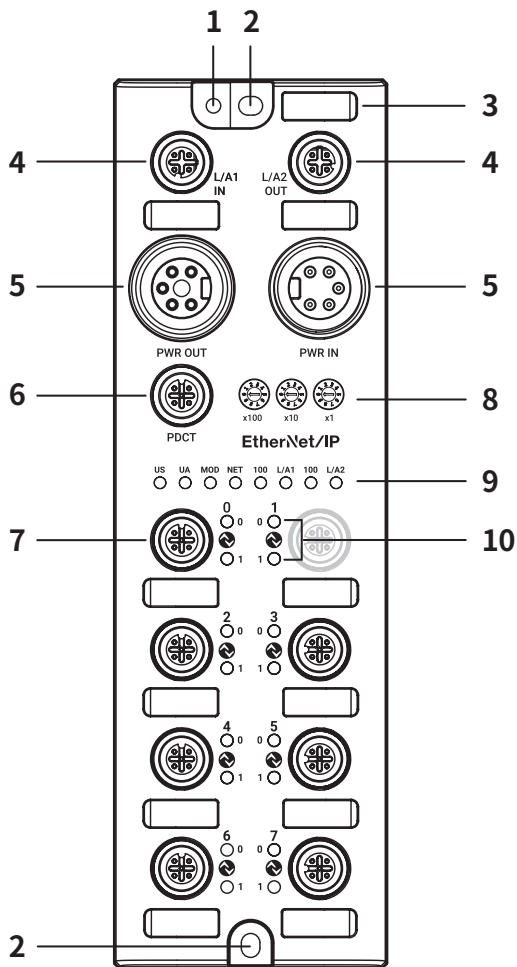

- 01. Grounding hole
- 02. Mounting hole
- 03. Insertion part for the name plate
- 04. Ethernet port
- 05. Power supply port
- 06. PDCT port
- 07. I/O port
- 08. Rotary switches
- 09. Status indicator
- 10. I/O port indicator

## Installation

### ■ Mounting

01. Prepare a flat or metal panel in the enclosure.
02. Drill a hole to mount and ground the product on the surface.
03. Turn off all power.
04. Fix the product using M4 screws in the mounting holes.  
Tightening torque: 1.5 N m

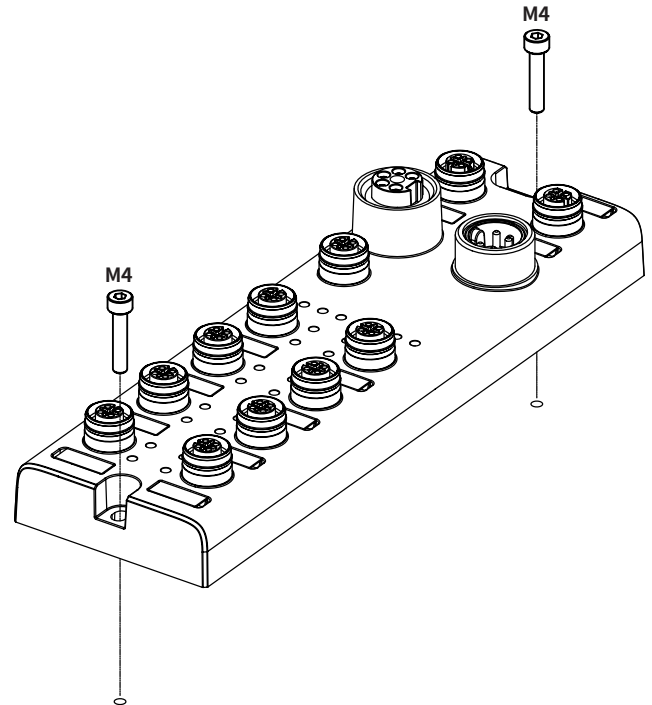

### ■ Grounding

⚠ Be sure to use a cable with low impedance and as short as possible for connecting the housing to the product.

01. Connect the grounding strap and M4×10 screw with washer.
02. Fix the screw in the grounding hole.  
Tightening torque: 1.2 N m

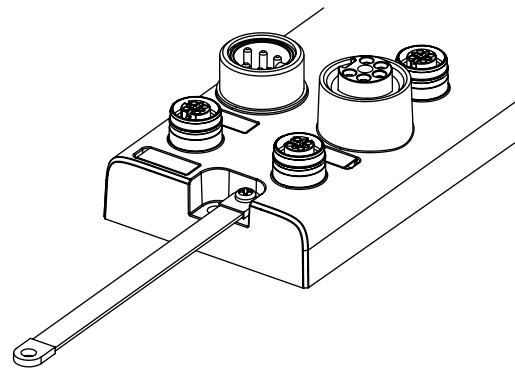

## IP Address Settings

To connect to the EtherNet/IP network, configure the EtherNet/IP interface. The IP address can be assigned using the following methods.

### ■ Rotary switches

⚠ Be sure to place the seal of the protective cover firmly on the rotary switches after completing the settings. The protection rating is not guaranteed when the protective cover is open.

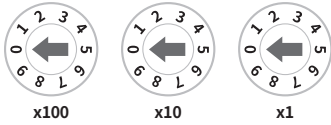

01. Rotate the rotary switches to set the mode and IP address. The green LED of the US indicator flashes.

Setting mode	Rotary switches	Description	Value
Default IP Address	000	This IP address is stored in the ADIO-EI's EEPROM. Applying the IP address set on the atIOLink software.	Factory settings: 192.168.2.3
Static IP Address	001 to 255	The IP address of the Ethernet port. Set the last octet of the IP address.	192.168.2.□□□
BOOTP	800 to 899	The IP address is assigned by the Bootstrap Protocol (BOOTP)-server.	IP Address, Subnet Mask., etc
DHCP	900 to 999	The IP address is assigned by the DHCP-server.	IP Address, Subnet Mask., etc

02. Turn on the ADIO-EI again.

03. Check that green LED of the US indicator is ON.

04. The IP address has been changed.

05. Put the protective cover on the rotary switches.

### ■ atIOLink

The address assigned by the atIOLink software is stored in the ADIO-EI's EEPROM. For more information, refer to the atIOLink User Manual.

Address	Description	Factory settings
Static IP Address	The default IP address of the ADIO-EI	192.168.2.3
Subnet Mask	The subnet mask of the IP network	255.255.255.0
Gateway Address	The IP address of the gateway	192.168.2.1

## Port Connections

### ■ Port specifications

- Be sure to check the port specifications below before connecting the device. Prepare a cable that complies with the protection rating IP67.

	Ethernet port	I/O port	PDCT port	Power supply port
Type	M12 (Socket-Female), 4-pin, D-coded	M12 (Socket-Female), 5-pin, A-coded	M12 (Socket-Female), 5-pin, A-coded	Input: 7/8" (Plug-Male), 5-pin Output: 7/8" (Socket-Female), 5-pin
Push-Pull	YES	YES	YES	N.A
Number of ports	2	8	1	2
Tightening torque	0.6 N m	0.6 N m	0.6 N m	1.5 N m
Supported function	Daisy chain	-	USB serial communication	Daisy chain

- The example of communication cable for the PDCT port

Connector 1	Connector 2	Wiring																								
M12 (Plug-Male)	USB Type A	<table border="1"> <thead> <tr> <th>Connector 1 Pin no.</th> <th>Connector 1 Function</th> <th>Connector 2 Pin no.</th> <th>Connector 2 Function</th> </tr> </thead> <tbody> <tr> <td>1</td> <td>N.C.</td> <td>1</td> <td>+5 VDC≡</td> </tr> <tr> <td>2</td> <td>Data -</td> <td>2</td> <td>Data -</td> </tr> <tr> <td>3</td> <td>0V</td> <td>4</td> <td>0V</td> </tr> <tr> <td>4</td> <td>N.C.</td> <td>-</td> <td>-</td> </tr> <tr> <td>5</td> <td>Data +</td> <td>3</td> <td>Data +</td> </tr> </tbody> </table>	Connector 1 Pin no.	Connector 1 Function	Connector 2 Pin no.	Connector 2 Function	1	N.C.	1	+5 VDC≡	2	Data -	2	Data -	3	0V	4	0V	4	N.C.	-	-	5	Data +	3	Data +
Connector 1 Pin no.	Connector 1 Function	Connector 2 Pin no.	Connector 2 Function																							
1	N.C.	1	+5 VDC≡																							
2	Data -	2	Data -																							
3	0V	4	0V																							
4	N.C.	-	-																							
5	Data +	3	Data +																							

### 01. Connect to the EtherNet/IP

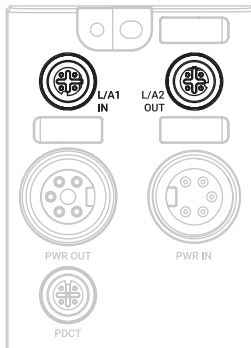

01. Connect the M12 connector to the Ethernet port. See the connections below.

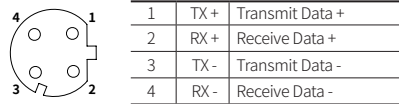

02. Connect the connector to the EtherNet/IP network.
  - Network device: PLC or EtherNet/IP device supporting EtherNet/IP protocol
03. Put the waterproof cover on the unused port.

### 02. Connect the IO-Link devices

- ⚠ The maximum output current is 2 A at each I/O port. Configure the device so that the total current of the I/O ports does not exceed 9 A.
- ⚠ Check the wiring information in the manual of the IO-Link device to be connected.

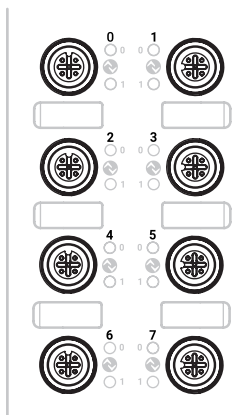

01. Connect the M12 connector to the I/O port. See the connections below.

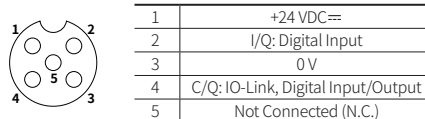

02. Put the waterproof cover on the unused port.

## 03. Connect with the atIOLink

⚠ Do not use the PDCT port and the Ethernet port at the same time.

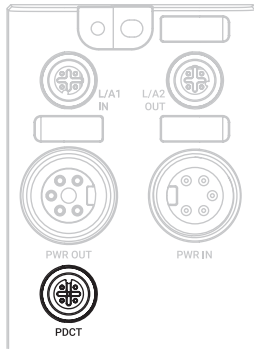

01. Connect the M12 connector to the PDCT port. See the connections below.



1	Not Connected (N.C.)
2	Data -
3	0 V
4	Not Connected (N.C.)
5	Data +

02. Connect the connector to the network device.

- Network device: PC/laptop that atIOLink software is installed

03. Put the waterproof cover on the unused port.

## 04. Connect the power supply to ADIO

⚠ Be sure not to exceed 9 A of the maximum supplying current to the sensor (US).

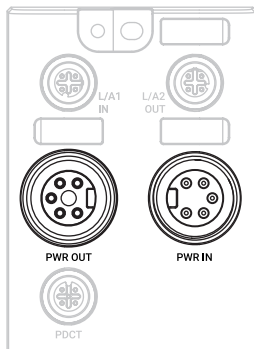

01. Turn off all power.

02. Connect the 7/8" connector to the power supply port. See the connections below.

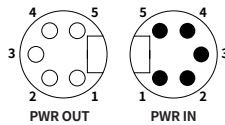

1, 2	0 V	Sensor and actuator supply
3	F.G.	Frame ground
4	+24 VDC	Sensor supply
5	+24 VDC	Actuator supply

## Indicators

### ■ Status indicator



#### 01. The power supply of sensor

Indicator	LED color	Status	Description
US	Green	ON	Applied voltage: normal
		Flashing (1 Hz)	The settings of the rotary switches is changing.
	Red	Flashing (1 Hz)	Applied voltage: low (< 18 VDC=)

#### 02. The power supply of actuator

Indicator	LED color	Status	Description
UA	Green	ON	Applied voltage: normal
	Red	Flashing (1 Hz)	Applied voltage: low (< 18 VDC=), Error in the rotary switches
		ON	Applied voltage: none (< 10 VDC=)

#### 03. Error status

Indicator	LED color	Status	Description
US, UA	Green	Flashing (1 Hz)	Error in the rotary switches (the applied voltage: normal)
	Red	ON	ADIO initialization failure

#### 04. Module status

Indicator	LED color	Status	Description
MOD	Green / Red	OFF	No error
		Flashing	Device self-testing: Power
	Green	ON	Operating
		Flashing	Standby: Device is not configured. (no IP address)
	Red	ON	Unrecoverable error (module failed)
		Flashing	Error in device configuration (invalid configuration)

#### 05. Network status

Indicator	LED color	Status	Description
NET	Green / Red	OFF	No Power and IP address
		Flashing	Device self-testing: Power
	Green	ON	The connection is established.
		Flashing	No connection
	Red	ON	IP address conflict: Another device has the same IP address.
		Flashing	Connection timeout

#### 06. Ethernet connection

Indicator	LED color	Status	Description
L/A1 L/A2	Green	OFF	No Ethernet connection
		ON	The Ethernet connection is established.
	Yellow	Flashing	Data transmission

#### 07. Transmission rate of the Ethernet

Indicator	LED color	Status	Description
100	Green	OFF	Transmission rate: 10 Mbps
		ON	Transmission rate: 100 Mbps

### ■ I/O port indicator

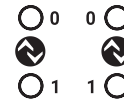

#### 01. Pin 4 (C/Q)

Indicator	LED color	Status	Description
0	Yellow	OFF	DI/DO: pin 4 OFF
		ON	DI/DO: pin 4 ON
	Green	ON	Port configuration: IO-Link
		Flashing (1 Hz)	Port configuration: IO-Link, No IO-Link device found
	Red	Flashing (2 Hz)	IO-Link configuration error • Validation failed, Invalid data length, Data Storage error
		ON	• NPN: Short circuit occurred on the output of pin 4 and pin 1 • PNP: Short circuit occurred on the output of pin 4 and pin 3

#### 02. Pin 2 (I/Q)

Indicator	LED color	Status	Description
1	Yellow	OFF	DI: pin 2 OFF
		ON	DI: pin 2 ON

#### 03. The power supply of the I/O port

Indicator	LED color	Status	Description
0,1	Red	Flashing (1 Hz)	Short circuit occurred in the I/O supply power (pin 1, 3)

## Specifications

### ■ Electrical/Mechanical specifications

Supply voltage	18 - 30 VDC≐
Rated voltage	24 VDC≐
Current consumption	2.4 W ( ≤ 216 W)
Supplying current per port	≤ 2 A/Port
Sensor current (US)	≤ 9 A
Dimensions	W 66 × H 215 × D 38 mm
Material	Zinc Die casting
Ethernet port	M12 (Socket-Female), 4-pin, D-coded, Push-Pull Number of ports: 2 (IN/OUT) Supported function: daisy chain
Power supply port	Input: 7/8" (Plug-Male), 5-pin Output: 7/8" (Socket-Female), 5-pin Number of ports: 2 (IN/OUT) Supported function: daisy chain
PDCT port	M12 (Socket-Female), 5-pin, A-coded, Push-Pull Number of ports: 1 Connection method: USB serial communication
I/O port	M12 (Socket-Female), 5-pin, A-coded, Push-Pull Number of ports: 8
Mounting method	Mounting hole: fixed with M4 screw
Grounding method	Grounding hole: fixed with M4 screw
Unit weight (packaged)	≈ 700 g (≈ 900 g)

### ■ Mode specifications

Mode	Digital Input
Number of channels	16-CH (I/Q: 8-CH, C/Q: 8-CH)
I/O common	NPN / PNP
Input current	5 mA
ON voltage/current	Voltage: ≥ 15 VDC≐ Current: ≥ 5 mA
OFF voltage	≤ 5 VDC≐

Mode	Digital Output
Number of channels	8-CH (C/Q)
I/O common	NPN / PNP
Power supply	24 VDC≐ (18 - 30 VDC≐), Max. 300 mA
Leakage current	≤ 0.1 mA
Residual voltage	≤ 1.5 VDC≐
Short circuit protection	YES

Mode	IO-Link
Input current	2 mA
ON voltage/current	Voltage: ≥ 15 VDC≐ Current: ≥ 2 mA
OFF voltage	≤ 5 VDC≐

### ■ Environmental conditions

Ambient temperature <sup>01)</sup>	-5 to 70 °C, Storage: -25 to 70 °C (no freezing or condensation)
Ambient humidity	35 to 75%RH (no freezing or condensation)
Protection rating	IP67 (IEC standard)

01) UL approved ambient temperature: 45 °C

### ■ Approvals

Approval	CE  
Association approval	 IO-Link EtherNet/IP

## Communication Interface

### ■ Ethernet

Ethernet standard	100BASE-TX
Cable spec.	STP (Shielded Twisted Pair) Ethernet cable over Cat 5
Transmission rate	10 / 100 Mbps
Cable length	≤ 100 m
Protocol	EtherNet/IP
Address settings	Rotary switches, DHCP, BOOTP, atIOLink
Factory settings	<ul style="list-style-type: none"> <li>• IP Address: 192.168.2.3</li> <li>• Subnet Mask: 255.255.255.0</li> <li>• Gateway Address: 192.168.2.1</li> </ul>
EDS file	Download the EDS file at the Autonics website.

### ■ IO-Link

Version	1.1
Transmission rate	COM1 : 4.8 kbps / COM2 : 38.4 kbps / COM3 : 230.4 kbps
Port class	Class A
Standard	IO-Link Interface and System Specification Version 1.1.2 IO-Link Test Specification Version 1.1.2