



導電性高分子ハイブリッドアルミ電解コンデンサ
CONDUCTIVE POLYMER HYBRID ALUMINUM ELECTROLYTIC CAPACITORS

CFV/CZF

CFV / CZF シリーズ SERIES

125°C 4,000時間品
125°C 4,000 hours
AEC-Q200

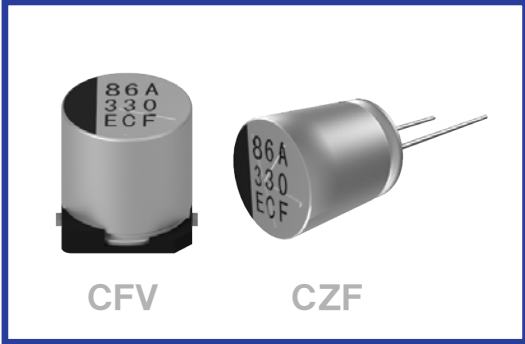

◆規格表 / SPECIFICATIONS

項目 Items	特 性 Characteristics								
カテゴリ温度範囲 Category Temperature Range	-55 ~ +125°C								
定格電圧範囲 Rated Voltage Range	25 ~ 63Vdc								
静電容量許容差 Capacitance Tolerance	±20% (20°C, 120Hz)								
漏れ電流 Leakage Current (MAX)	I=0.01CV又は3μAのいずれか大なる値以下 (定格電圧印加2分後) I=0.01CV or 3μA whichever is greater. (After 2 minute) I=漏れ電流(μA) C=静電容量(μF) V=定格電圧(Vdc) I = Leakage Current C = Capacitance V = Rated Voltage								
耐久 性 ① Endurance (1)	125°C中で4000時間定格電圧(定格リプル重畳)印加後、下記の規格を満足すること。 After applying rated voltage with rated ripple current for 4000 hours at 125°C, the capacitors shall meet the following Criteria.								
耐久 性 ② Endurance (2)	125°C中で3000時間定格電圧(定格リプル重畳)印加後、下記の規格を満足すること。 After applying rated voltage with rated ripple current for 3000 hours at 125°C, the capacitors shall meet the following Criteria.								
高温高湿負荷 Biased Humidity	85°C、85% RH中で2000時間定格電圧印加後、下記の規格を満足すること。 After applying rated voltage for 2000 hours at 85°C and humidity of 85%, the capacitors shall meet the following Criteria.								
規 格 Criteria	<table border="1"> <tr> <td>静電容量変化率 Capacitance Change</td> <td>初期値の ±30%以内 Within ±30% of the initial value.</td> </tr> <tr> <td>損失角の正接 Dissipation Factor</td> <td>規定値の 200%以下 Not more than 200% of the specified value.</td> </tr> <tr> <td>等価直列抵抗 ESR</td> <td>規格値の 200% 以下 Not more than 200% of the specified value.</td> </tr> <tr> <td>漏れ電流 Leakage Current</td> <td>規格値以下 Not more than the specified value.</td> </tr> </table>	静電容量変化率 Capacitance Change	初期値の ±30%以内 Within ±30% of the initial value.	損失角の正接 Dissipation Factor	規定値の 200%以下 Not more than 200% of the specified value.	等価直列抵抗 ESR	規格値の 200% 以下 Not more than 200% of the specified value.	漏れ電流 Leakage Current	規格値以下 Not more than the specified value.
静電容量変化率 Capacitance Change	初期値の ±30%以内 Within ±30% of the initial value.								
損失角の正接 Dissipation Factor	規定値の 200%以下 Not more than 200% of the specified value.								
等価直列抵抗 ESR	規格値の 200% 以下 Not more than 200% of the specified value.								
漏れ電流 Leakage Current	規格値以下 Not more than the specified value.								
低温特性 Low Temperature Stability (インピーダンス比) Impedance Ratio (MAX)	$Z(-25^{\circ}\text{C}) / Z(+20^{\circ}\text{C}) \leq 1.5$ (100kHz) $Z(-55^{\circ}\text{C}) / Z(+20^{\circ}\text{C}) \leq 2.0$								

◆呼称方法 / PART NUMBER



◆表示 / MARKING

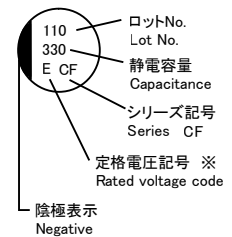

※電圧記号 Voltage Code

定格電圧 Rated Voltage (Vdc)	25	35	50	63
電圧記号 Voltage Code	E	V	H	J



導電性高分子ハイブリッドアルミ電解コンデンサ CONDUCTIVE POLYMER HYBRID ALUMINUM ELECTROLYTIC CAPACITORS

CFV/CZF

◆寸法図／DIMENSIONS

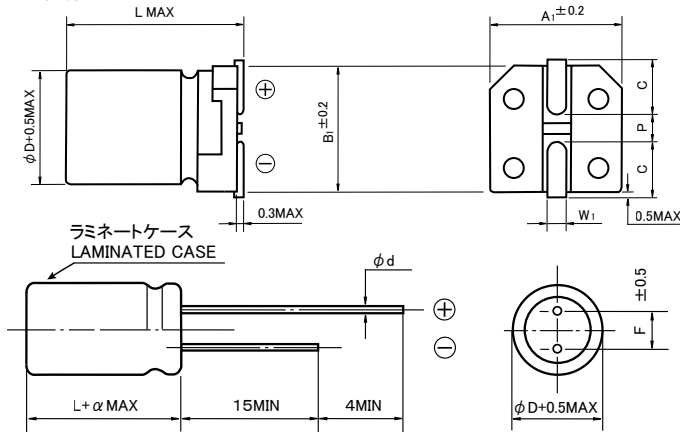

(mm)						
φD	L	A1	B1	C	W1	P
6.3	6.1	6.6	6.6	2.7	0.5~0.8	1.8
6.3	8	6.6	6.6	2.7	0.5~0.8	1.8
8	10.5	8.3	8.3	2.9	0.8~1.1	3.1
10	10.5	10.3	10.3	3.2	0.8~1.1	4.5

(mm)				
φD	L	F	φd	α
8	9	3.5	0.6	1.5
10	9	5.0	0.6	1.5

◆標準品一覧表／STANDARD SIZE

定格電圧 Rated Voltage (Vdc)	静電容量 Capacitance (μF)	外形寸法 Size φD X L (mm)		損失角の正接 (Tan δ) 120Hz, 20°C	等価直列抵抗 ESR (mΩ MAX) 20°C, 100kHz	定格リップル電流 Rated Ripple Current (mA rms / 125°C, 100kHz)	
		CFV series (SMD)	CZF series (Radial Lead type)			耐久性① Endurance (1)	耐久性② Endurance (2)
25	56	6.3×6.1	—	0.14	50	900	—
	100	6.3×8	—	0.14	30	1400	—
	220	8×10.5	8×9	0.14	27	1600	1900
	330	10×10.5	10×9	0.14	20	2000	2900
35	47	6.3×6.1	—	0.12	60	900	—
	68	6.3×8	—	0.12	35	1400	—
	150	8×10.5	8×9	0.12	27	1600	1900
	270	10×10.5	10×9	0.12	20	2000	2800
50	22	6.3×6.1	—	0.10	80	750	—
	33	6.3×8	—	0.10	40	1100	—
	68	8×10.5	8×9	0.10	30	1250	—
	100	10×10.5	10×9	0.10	28	1600	—
63	10	6.3×6.1	—	0.08	120	700	—
	22	6.3×8	—	0.08	80	900	—
	33	8×10.5	8×9	0.08	40	1100	—
	56	10×10.5	10×9	0.08	30	1400	—

◆リップル電流補正係数／MULTIPLIER FOR RIPPLE CURRENT

静電容量 Capacitance (C)	周波数 Frequency (f)	100Hz ≤ f < 200Hz	200Hz ≤ f < 300Hz	300Hz ≤ f < 500Hz	500Hz ≤ f < 1kHz
C < 47 μF	補正係数 Coefficient	0.10	0.10	0.15	0.20
47 μF ≤ C < 150 μF		0.15	0.20	0.25	0.30
150 μF ≤ C		0.15	0.25	0.25	0.30
静電容量 Capacitance (C)	周波数 Frequency (f)	1kHz ≤ f < 2kHz	2kHz ≤ f < 3kHz	3kHz ≤ f < 5kHz	5kHz ≤ f < 10kHz
C < 47 μF	補正係数 Coefficient	0.30	0.40	0.45	0.50
47 μF ≤ C < 150 μF		0.40	0.45	0.55	0.60
150 μF ≤ C		0.45	0.50	0.60	0.65
静電容量 Capacitance (C)	周波数 Frequency (f)	10kHz ≤ f < 15kHz	15kHz ≤ f < 20kHz	20kHz ≤ f < 30kHz	30kHz ≤ f < 40kHz
C < 47 μF	補正係数 Coefficient	0.60	0.65	0.75	0.75
47 μF ≤ C < 150 μF		0.70	0.75	0.80	0.80
150 μF ≤ C		0.75	0.80	0.85	0.85
静電容量 Capacitance (C)	周波数 Frequency (f)	40kHz ≤ f < 50kHz	50kHz ≤ f < 100kHz	100kHz ≤ f < 500kHz	500kHz ≤ f
C < 47 μF	補正係数 Coefficient	0.80	0.85	1.00	1.05
47 μF ≤ C < 150 μF		0.85	0.90	1.00	1.00
150 μF ≤ C		0.85	0.90	1.00	1.00

◆耐久試験後の ESR 値 (−40°C, 100kHz) / ESR AFTER ENDURANCE TEST (−40°C, 100kHz)

サイズ Size	6.3×6.1	6.3×8	8×10.5	10×10.5
ESR (Ω)	1.4	0.8	0.4	0.3